

### REMOVAL

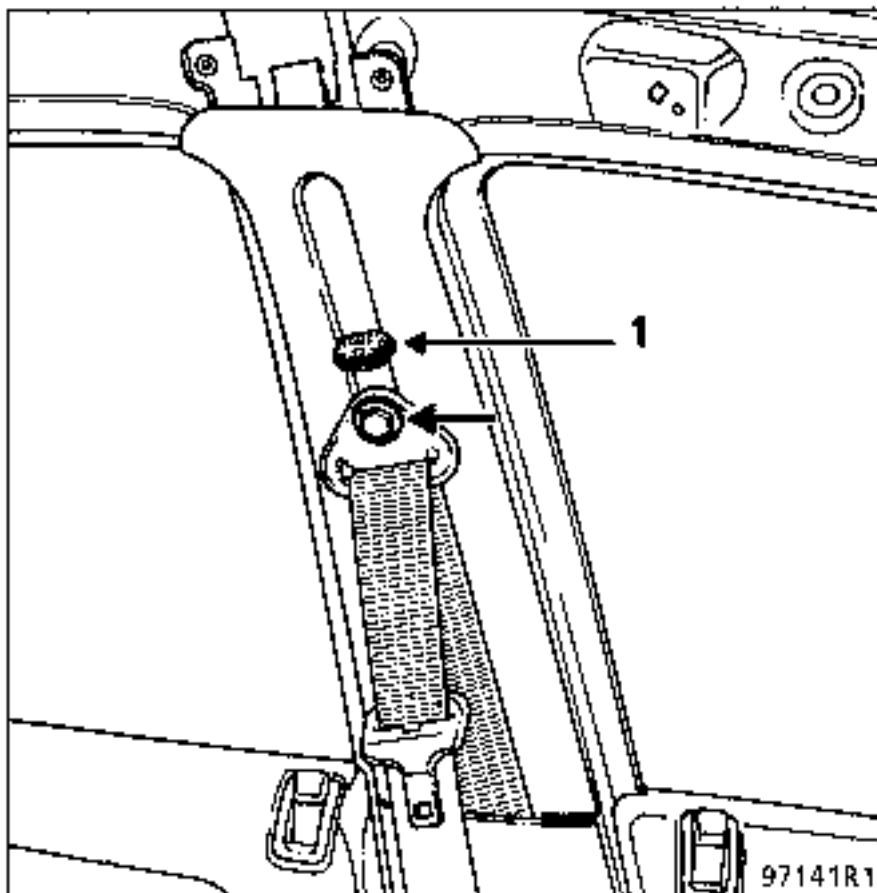

#### Remove:

- partially, the sections concerned of the door seals,
- the upper seat belt mounting cover.
- the adjusting button (1) (see 59A),
- the upper seat belt mounting bolt (17 spanner).

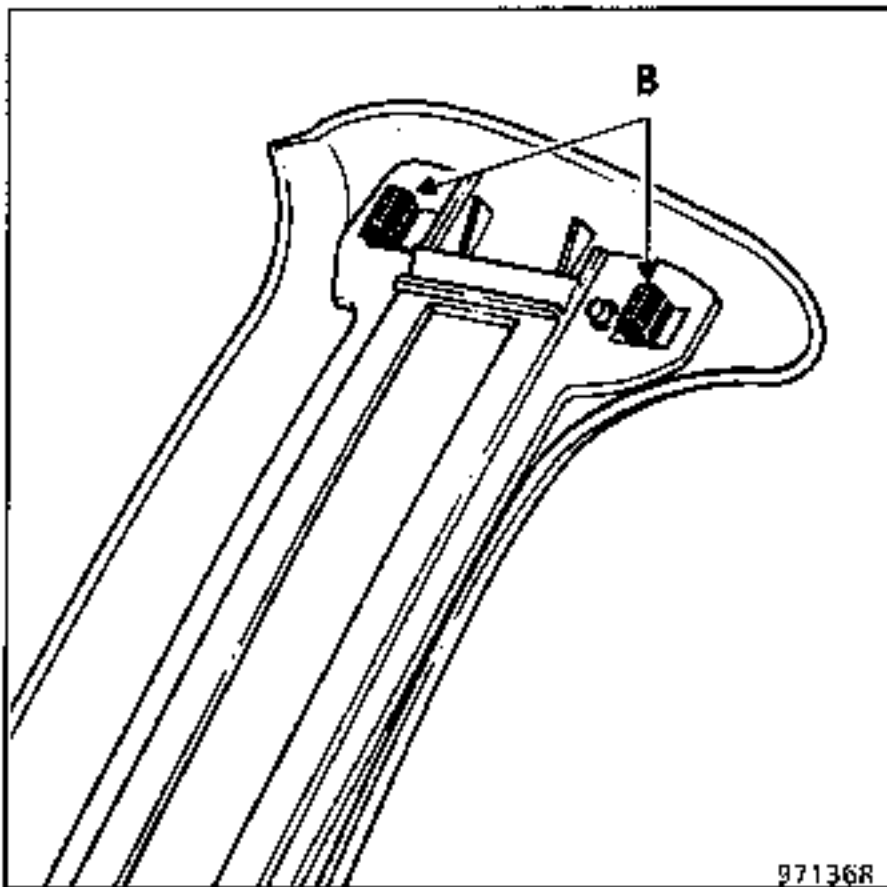

REFITTING

When refitting the lining, the height adjustment mechanism and its cover on the lining should be positioned in the low position (see 59A).

Unclip the upper part of the lining (inner view) (B).

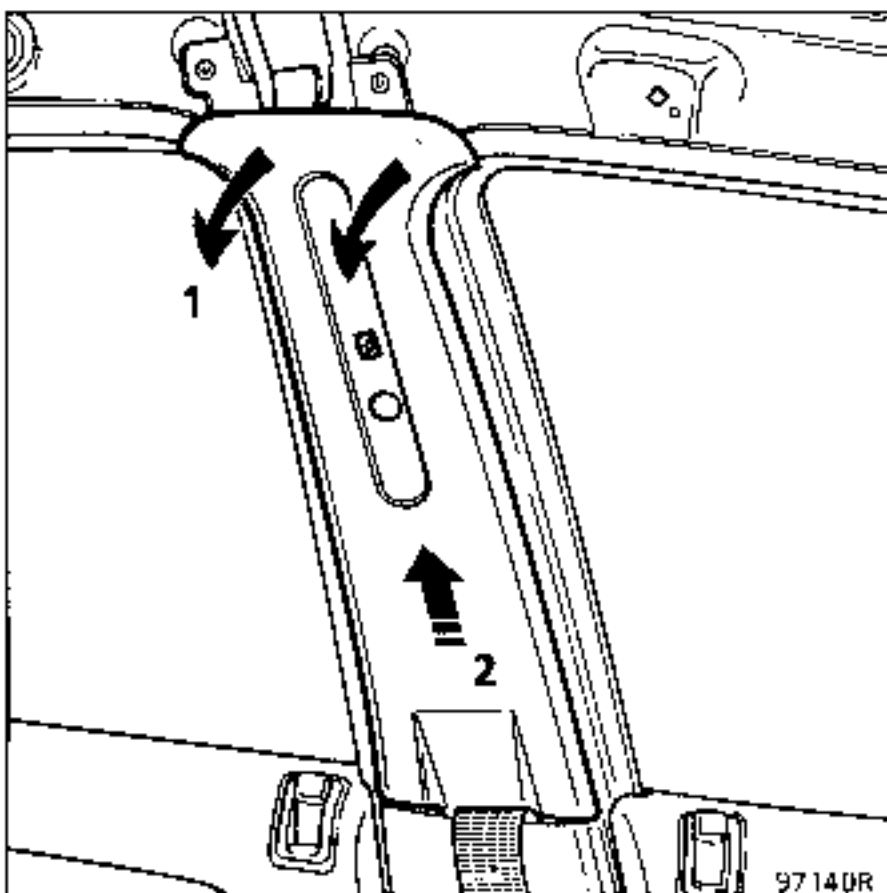

Remove the lining upwards.

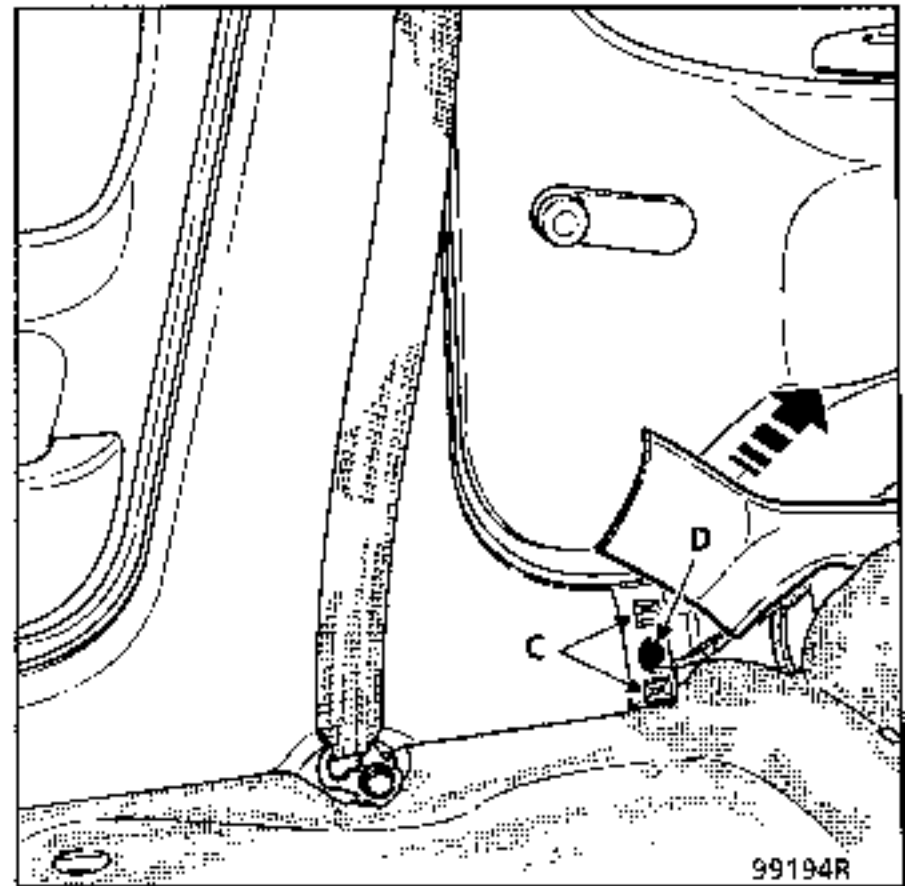
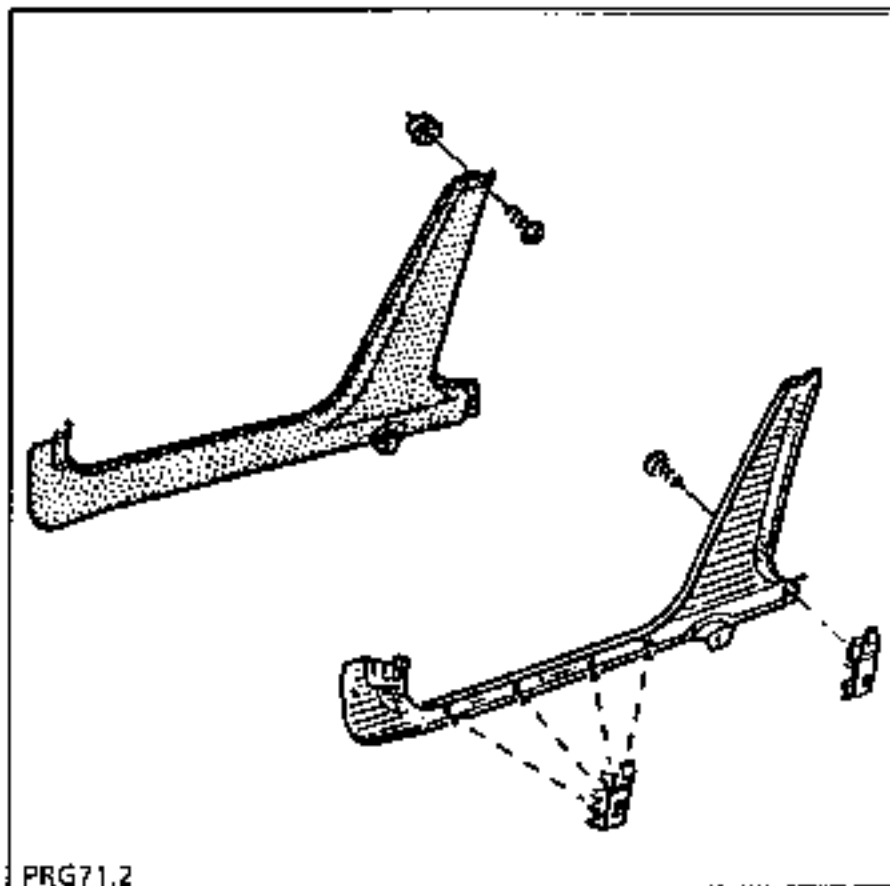

Unclip the front section of the rear pillar lining at (C).

Remove bolt (D).

Remove the lower mounting for the front seat belt (see 59B).

REMOVAL

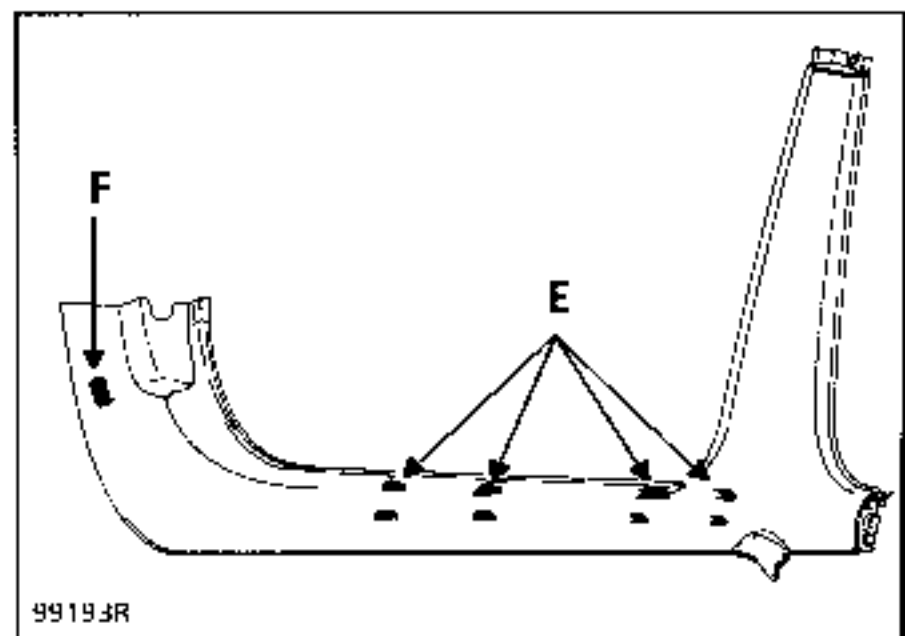
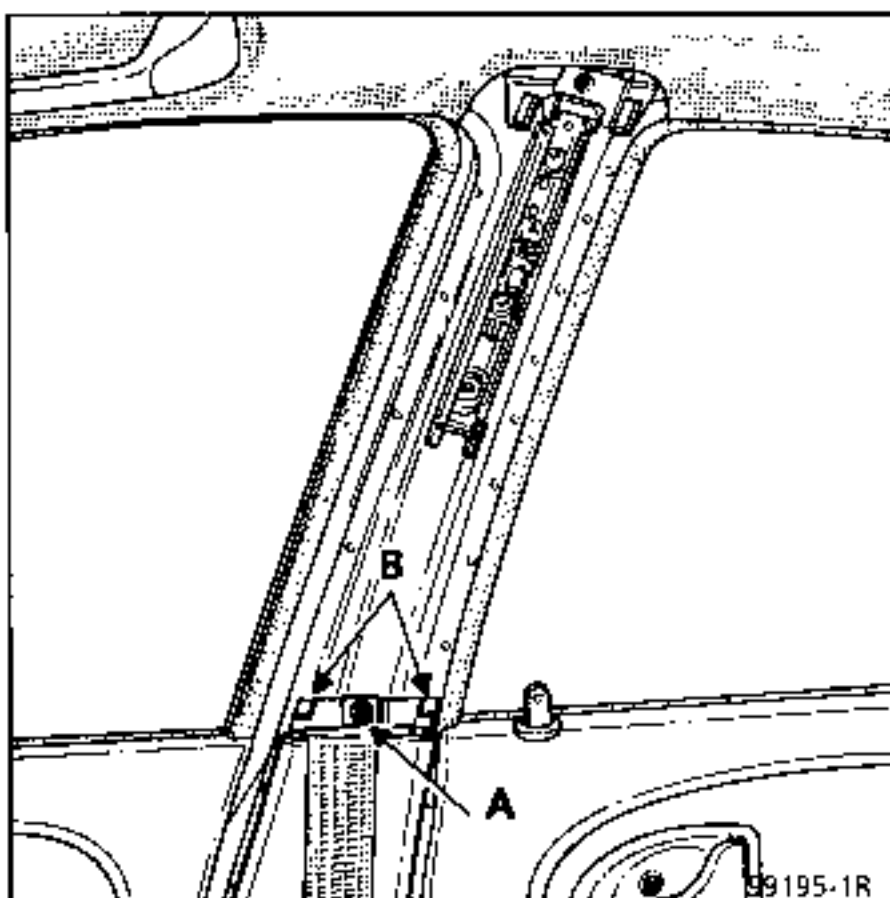

Unclip the four clips (E), starting at the rear of the vehicle.

Release bracket (F) to remove the lining.

Remove:

- the upper centre pillar lining (see 71A),
- bolt (A) and separate the two brackets (B) to remove the seat belt,
- the front and rear door seals.

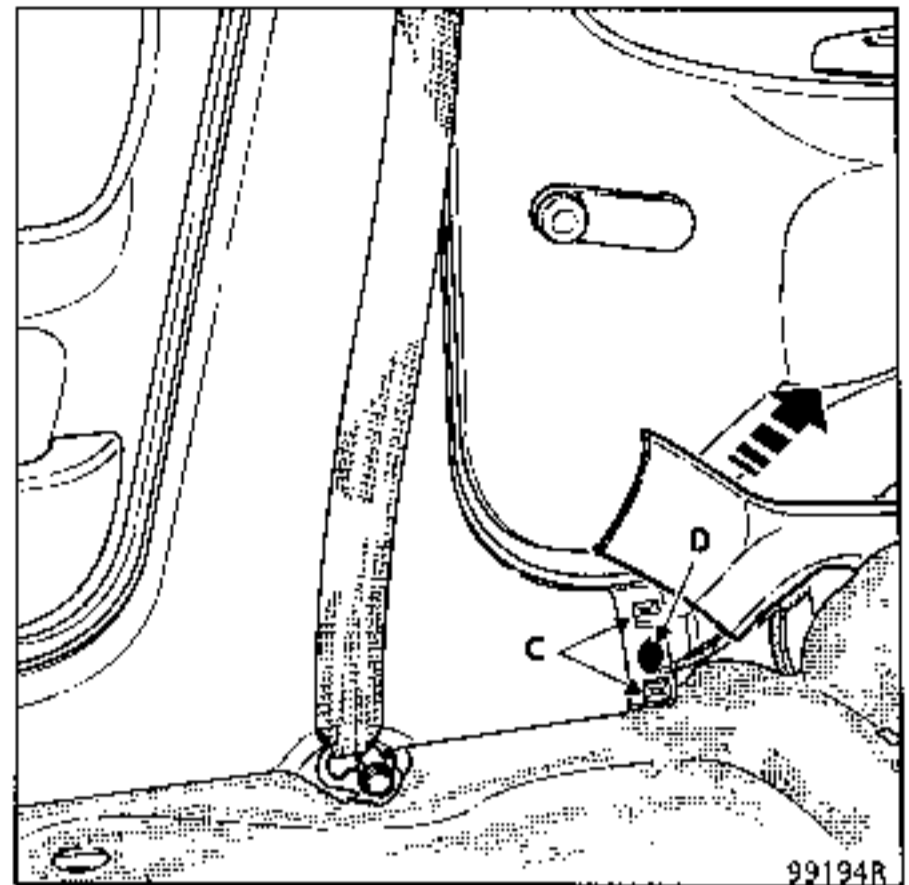
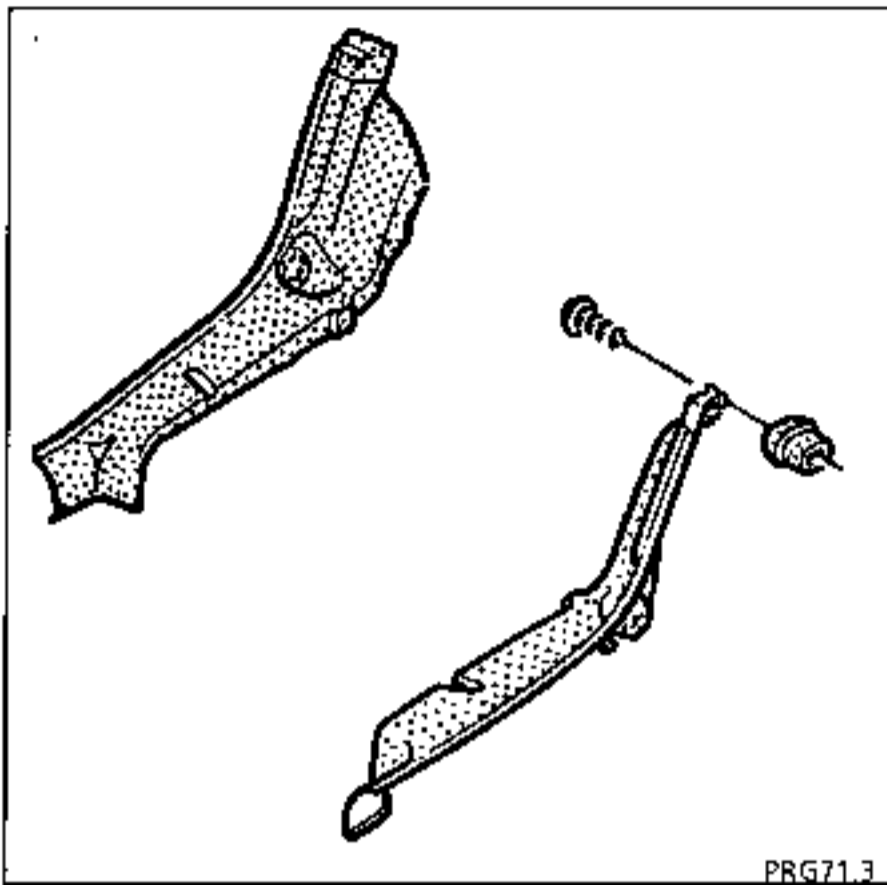

Release the two clips (C) while pulling on the lining.

### REMOVAL

- Remove :
- the rear door seal and the luggage compartment seal,
  - the rear side shelf (see 74A),
  - the rear upper valance lining (see 71 D).

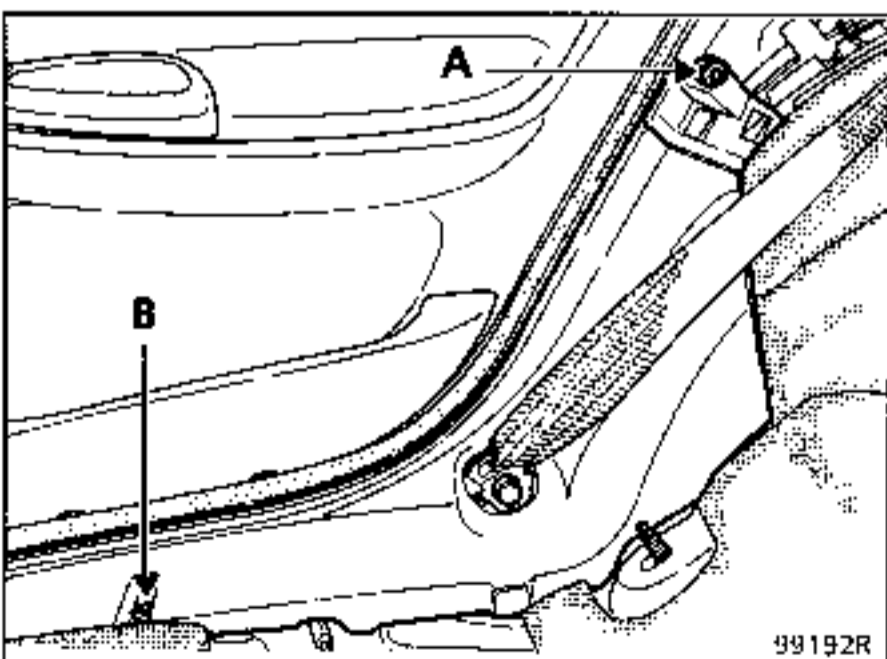

- Remove bolt (A).  
Lift the rear seat.  
Remove the lower mounting for the rear seat belt.  
Remove bolt (B).

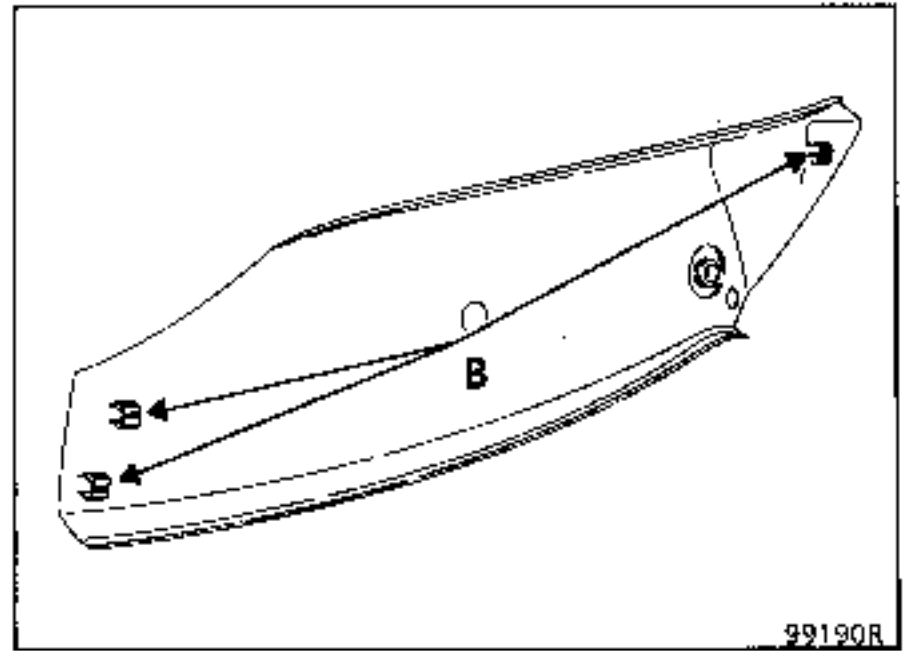
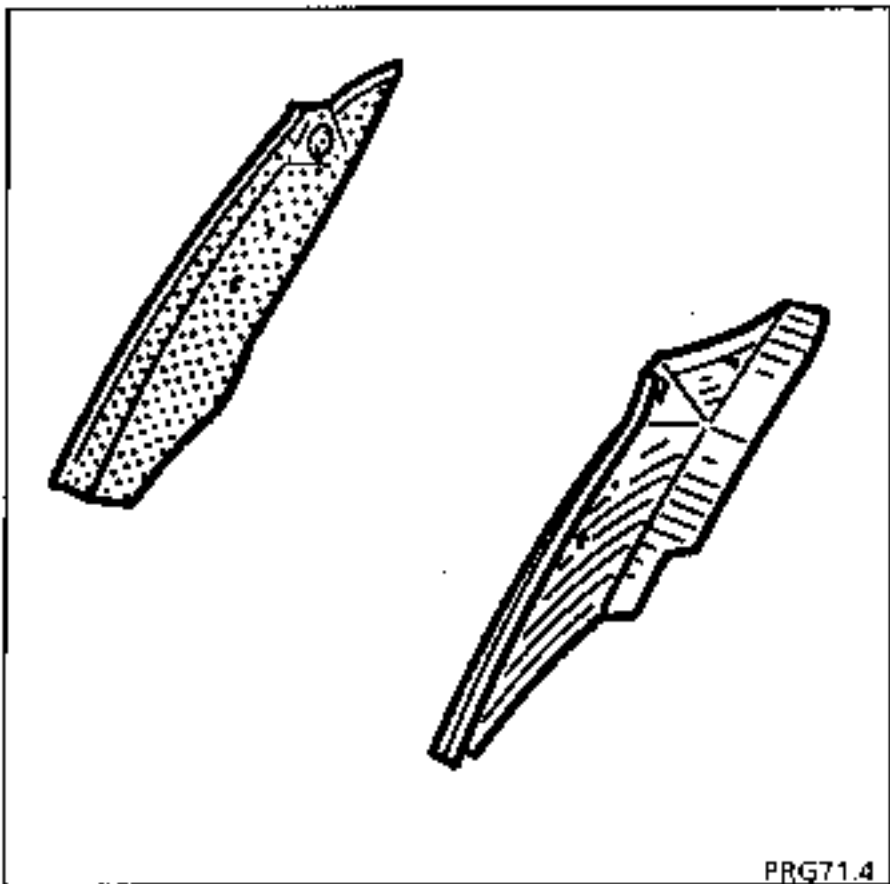

Release the three clips (B), while pulling on the lining.

## REMOVAL

- Remove :
- the rear central tray and the rear side tray (see 74 A),
  - the rear door seal.

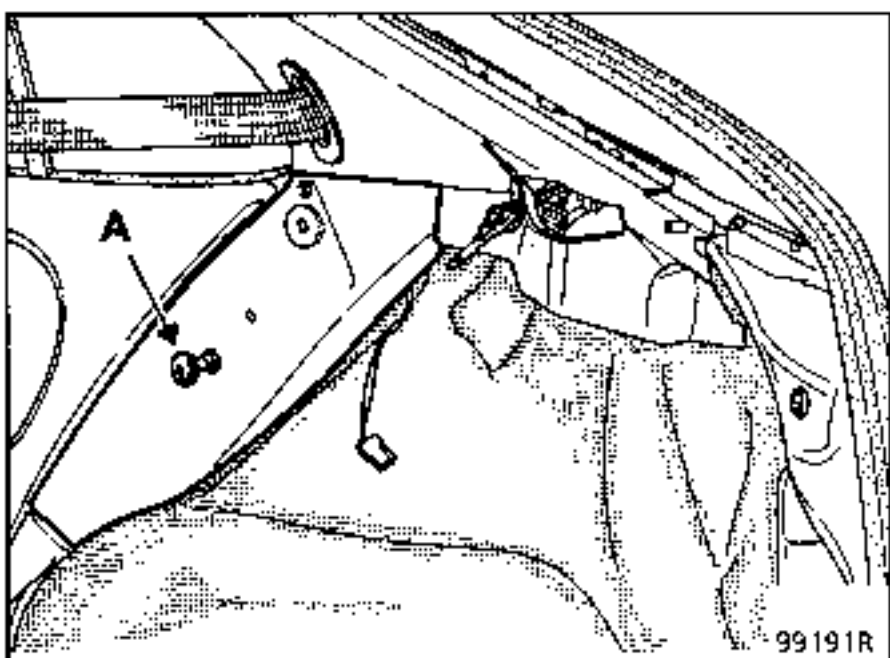

Remove the seat locking pin (A).

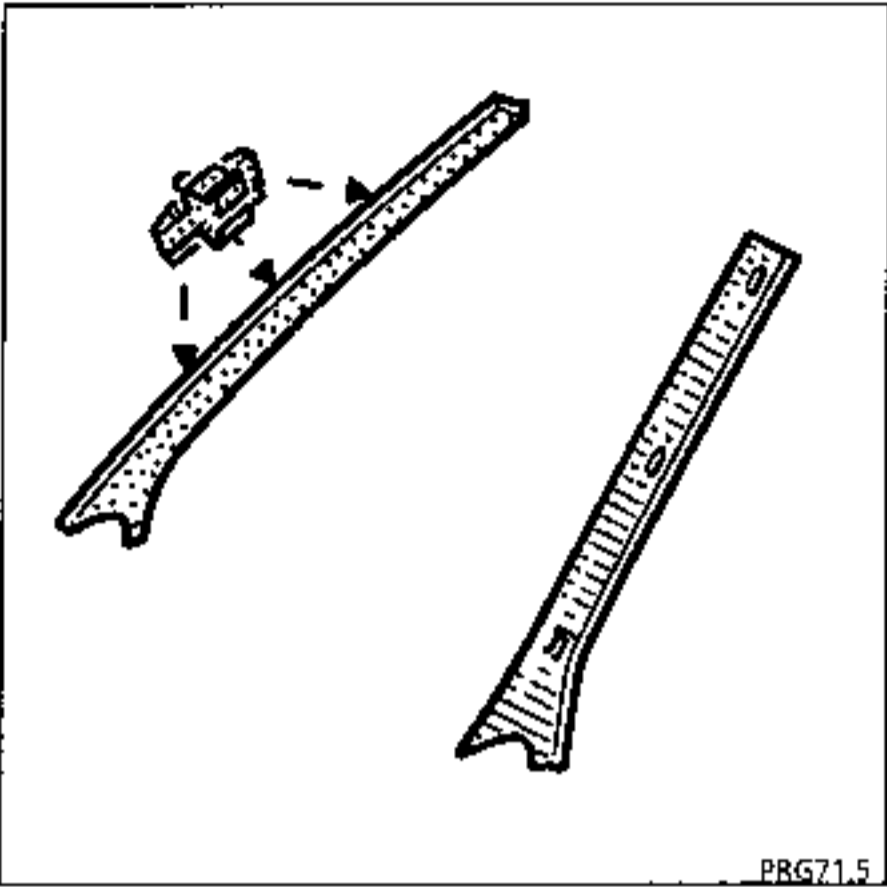

When refitting, begin by sliding the lining panel along the windscreen pillar to fit clip (B) before securing the two clips (A).

REMOVAL

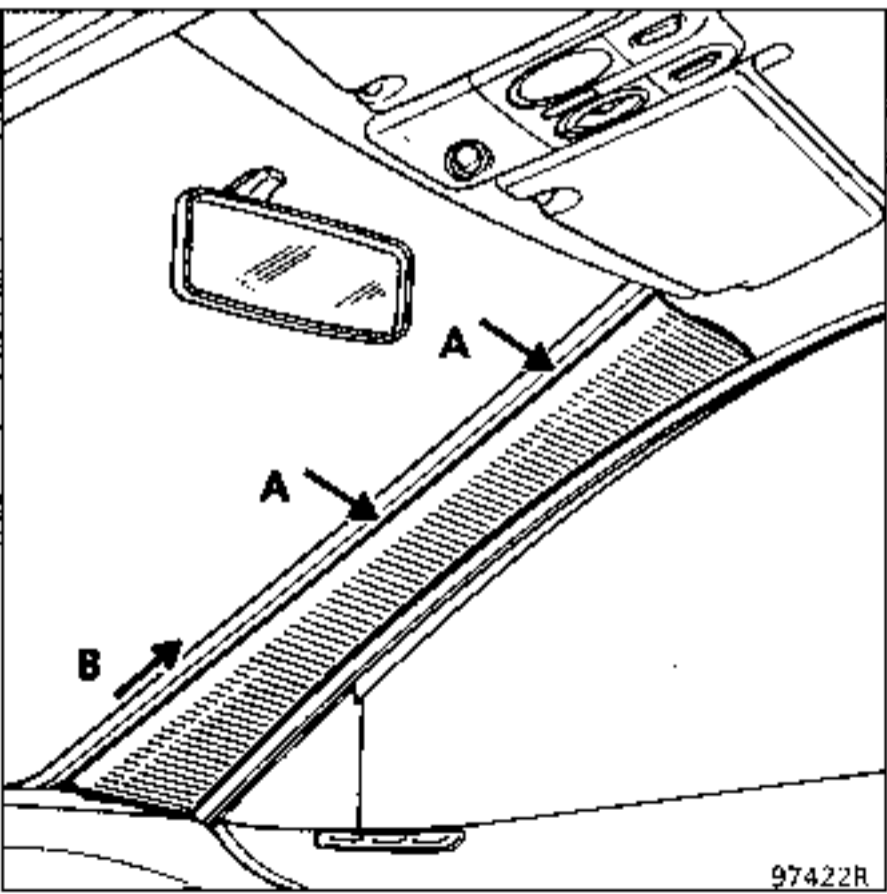

Partially remove the door frame seal in the area of the lining panel.  
Carefully unclip the two upper clips (A).  
Pull the lining towards the rear of the vehicle to release the third clip (B).

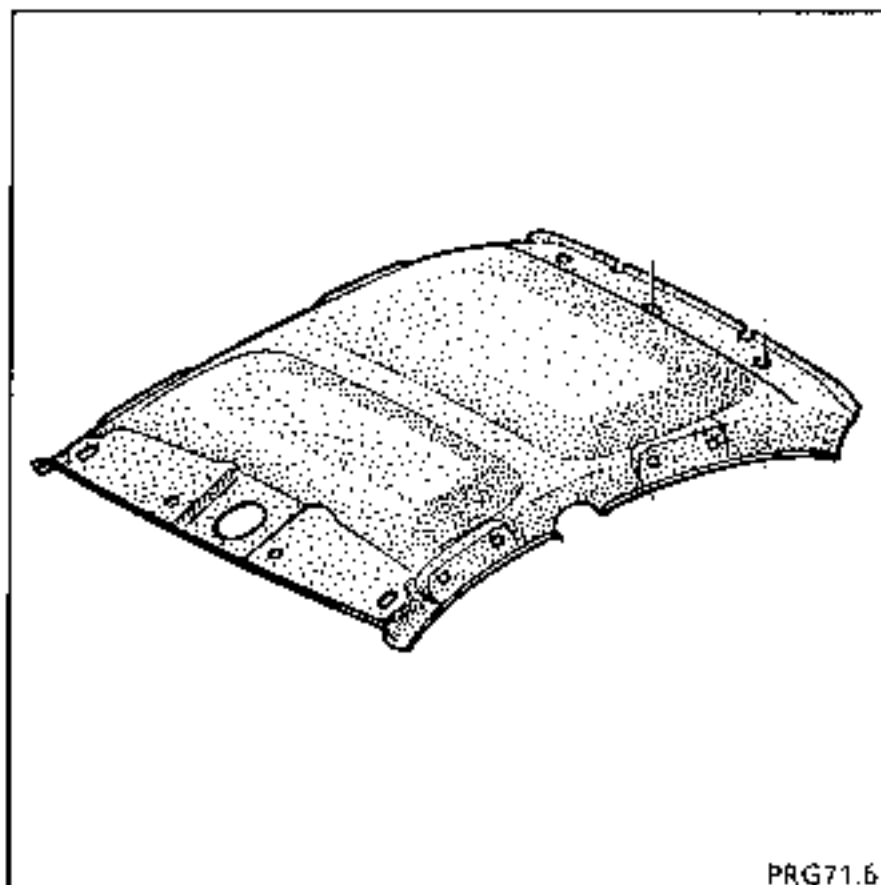

REMOVAL

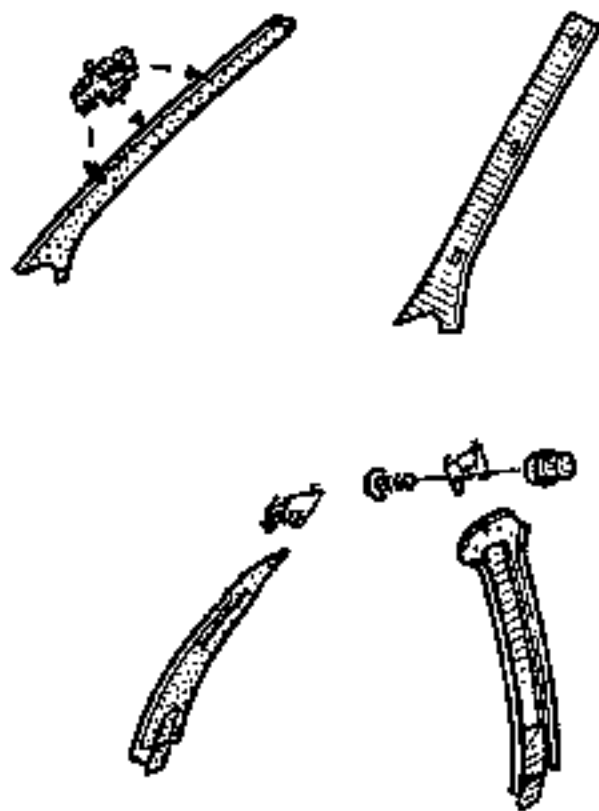

- Remove :
- the four door seals,
  - the luggage compartment seal (upper section only),
  - the windscreen pillar linings (see 71E),
  - the upper centre pillar linings (see 71A).

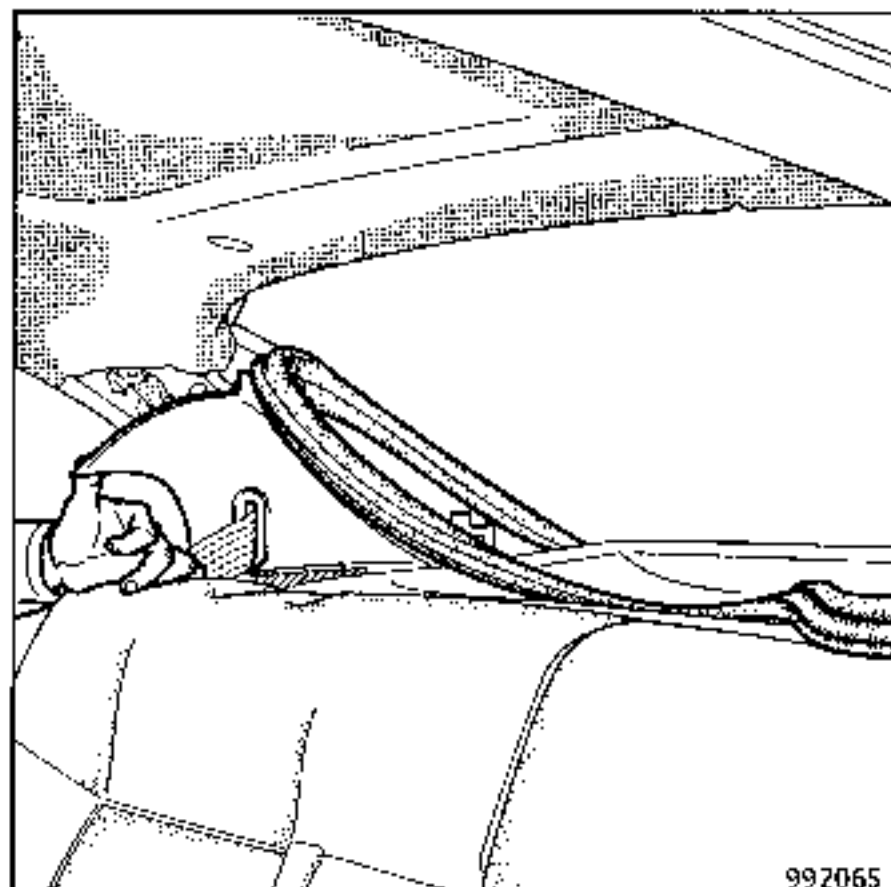

Unclip the two clips for each rear quarter panel lining from the contact area with the headlining.

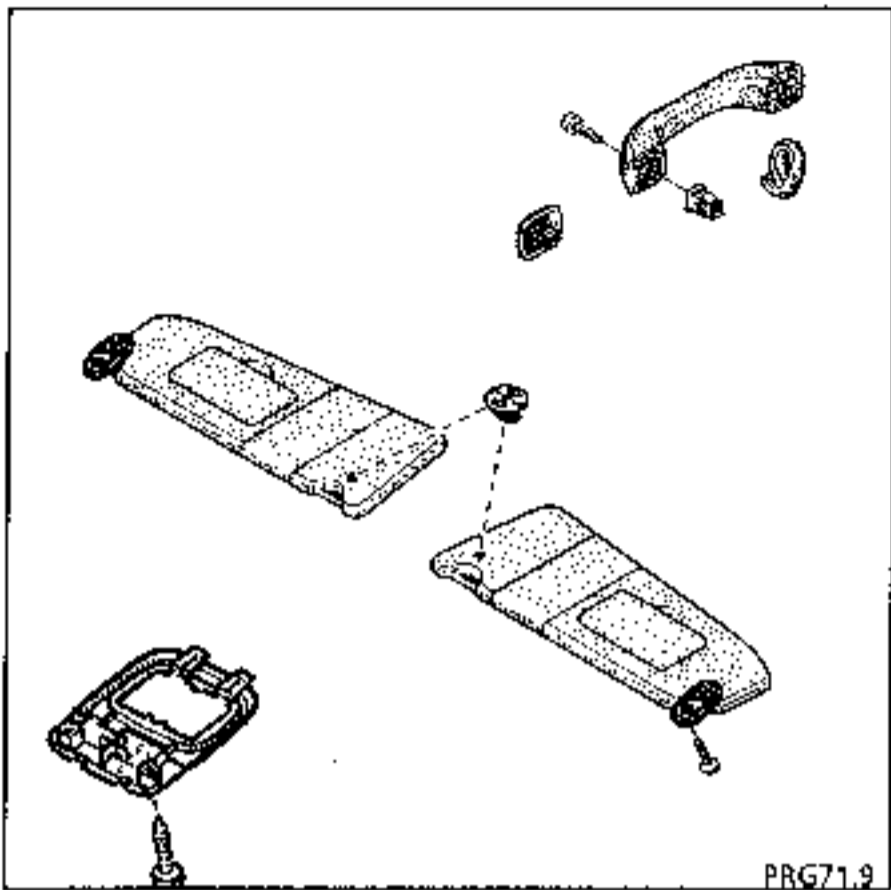

**Remove :**

- the sun visors and their retaining clips (see 58B),
- the grab handles and the blanking plugs on the driver's side (see 58A),
- the roof console (see 58C).

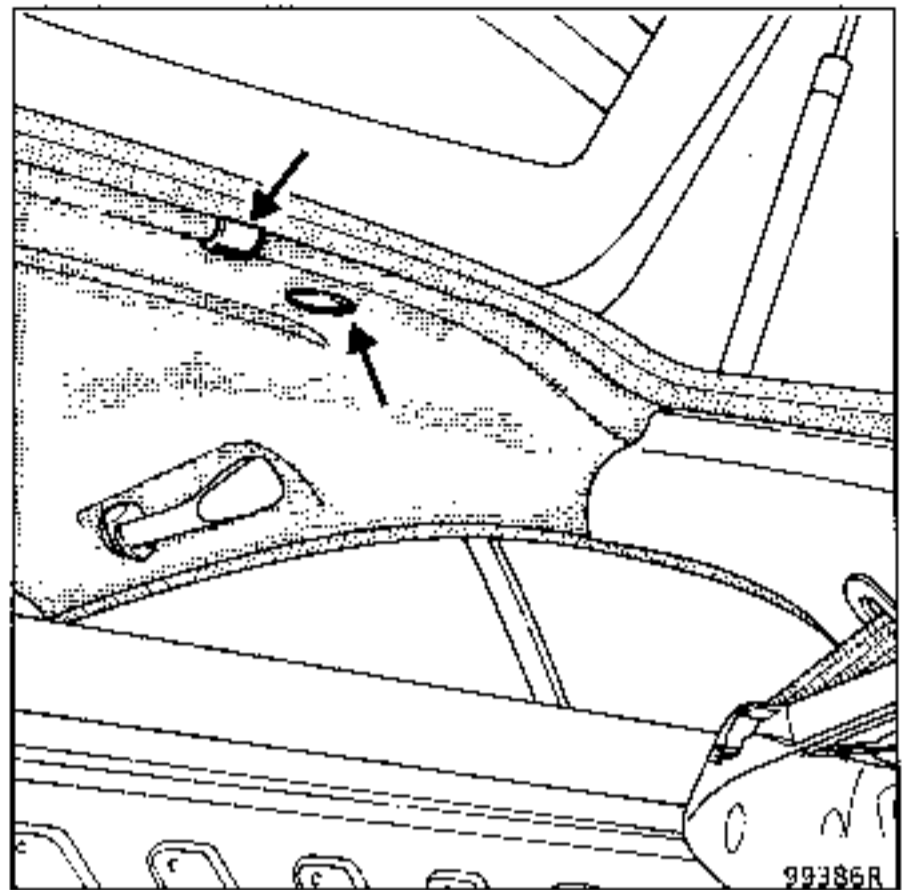

**Remove:**

- the tailgate mounting blanking plugs,
- the upper mountings for the rear sun screens (see below).

Press at (A) and remove the clip (B).

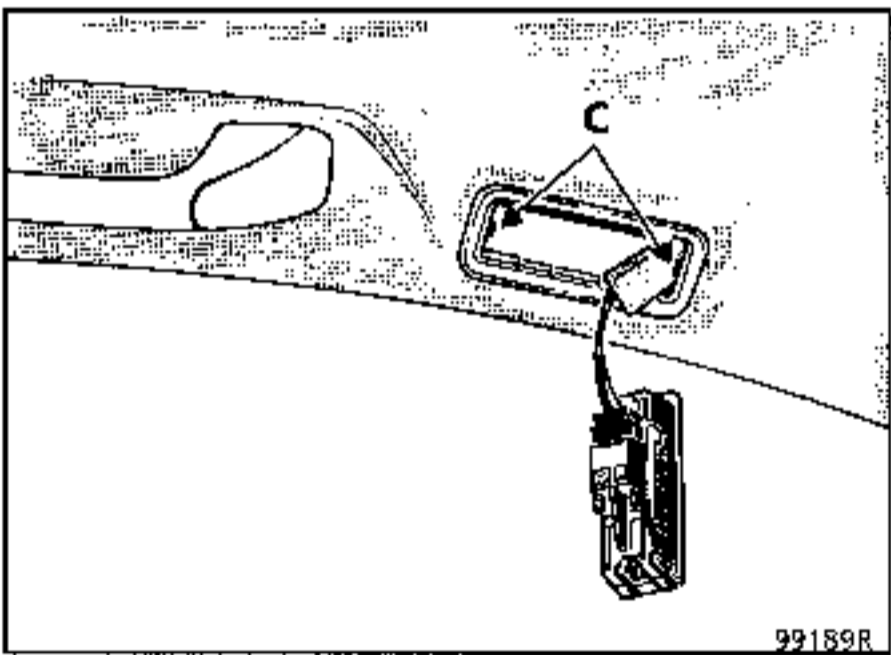

Release the two clips (C) securing the courtesy lights positioned next to the rear quarter panel linings.

Disconnect the connectors to remove the courtesy lights.

Remove their housings.

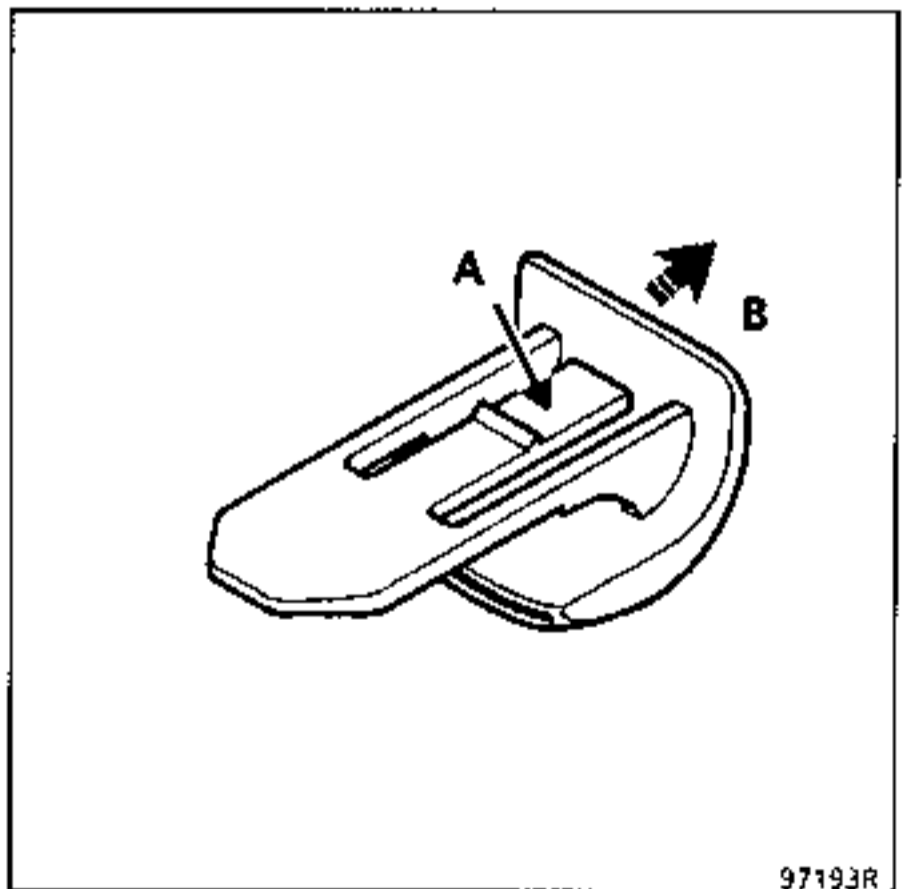

Release the headlining with care.  
Cut the adhesive beads using a tool (mastic knife).

Fold the rear seat down.  
Remove the headlining through the luggage compartment.



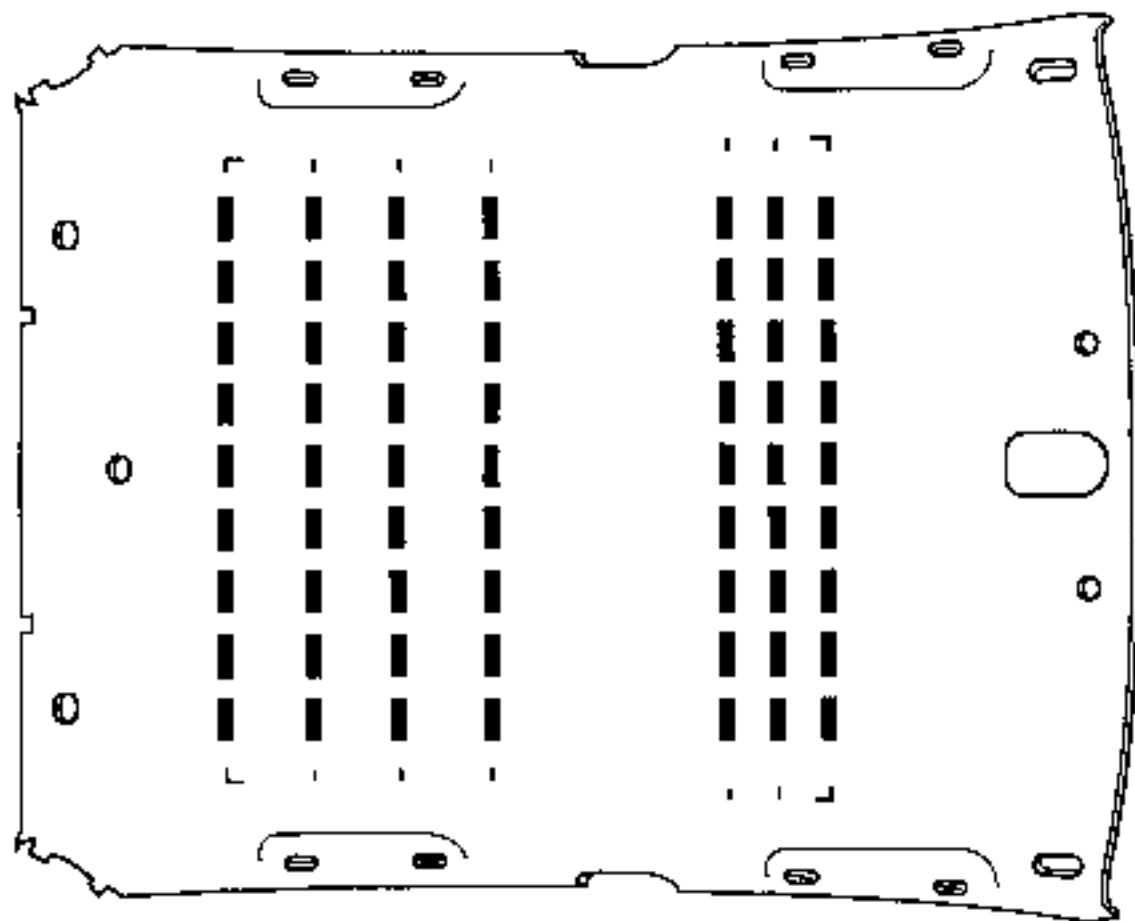

995805

After protecting the seats, apply adhesive to the headlining as shown below: Seven 4 mm diameter cylindrical beads should be applied between the reference marks on the headlining.

Bring the headlining into the vehicle via the luggage compartment.

Position the headlining in relation to the cut-outs for the sun visors and grab handles.

**This operation requires at least three persons.**

**NOTE:** For bonding the headlining use a single pot PU adhesive (windscreen adhesive type).

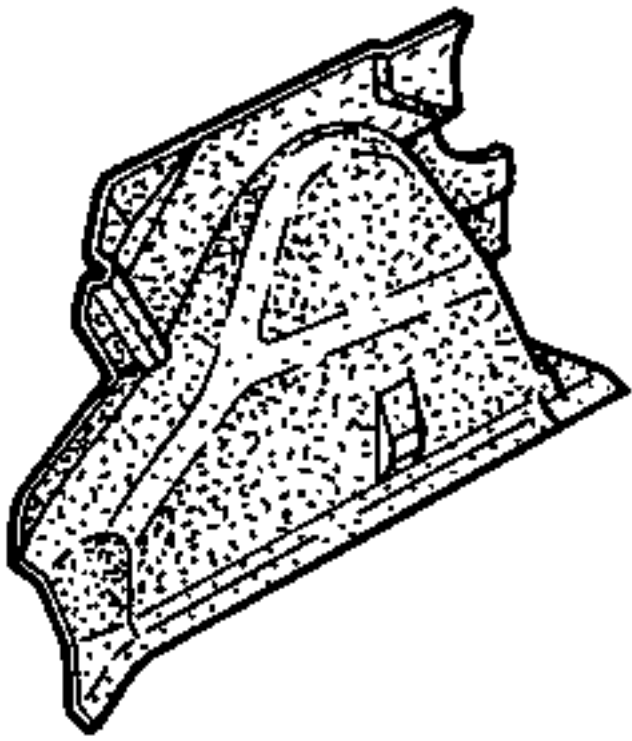

PRG71.8

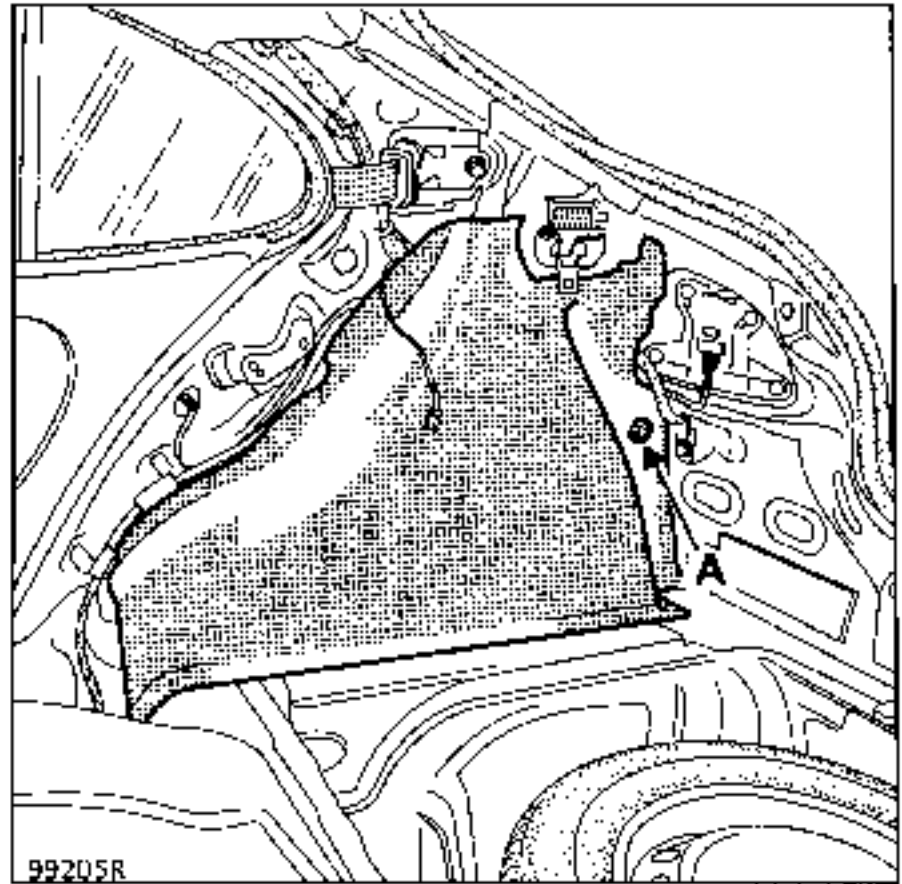

99205R

### REMOVAL

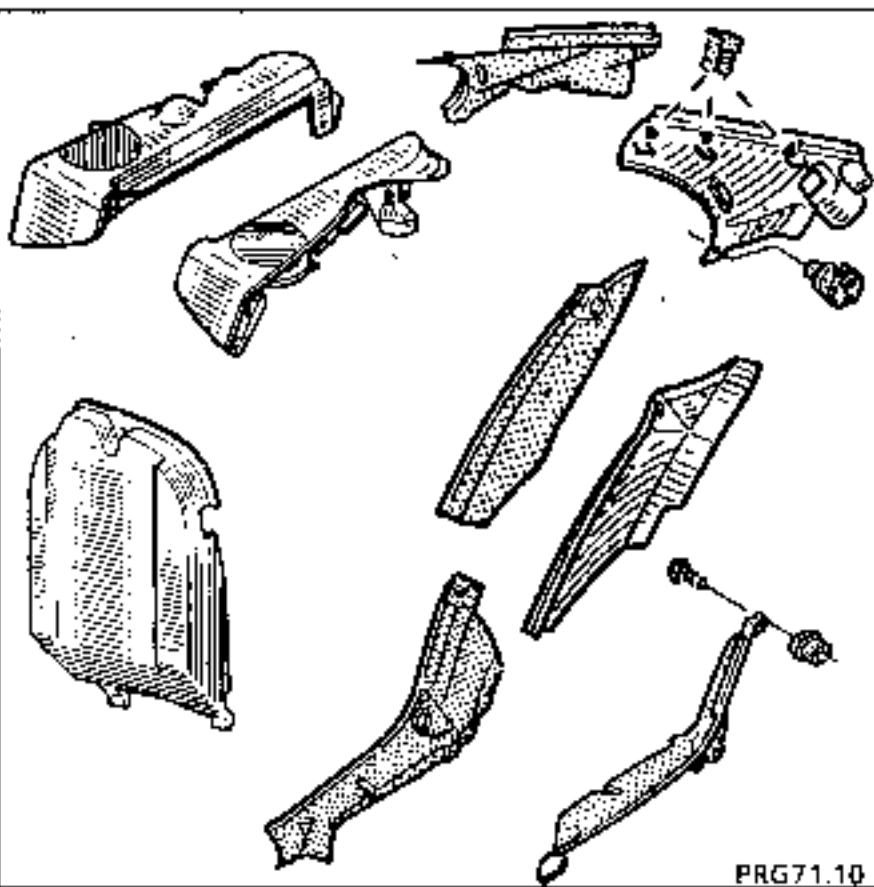

PRG71.10

Fold the rear seat down and lift the luggage compartment carpet.  
Remove the retaining clip (A) and remove the lining.

### Remove:

- the rear side shelf (see 74A),
- the upper and lower rear valance linings (see 71C/71D),
- the rear quarter panel lining (see 71H),
- the rear wing lining (see 71J).

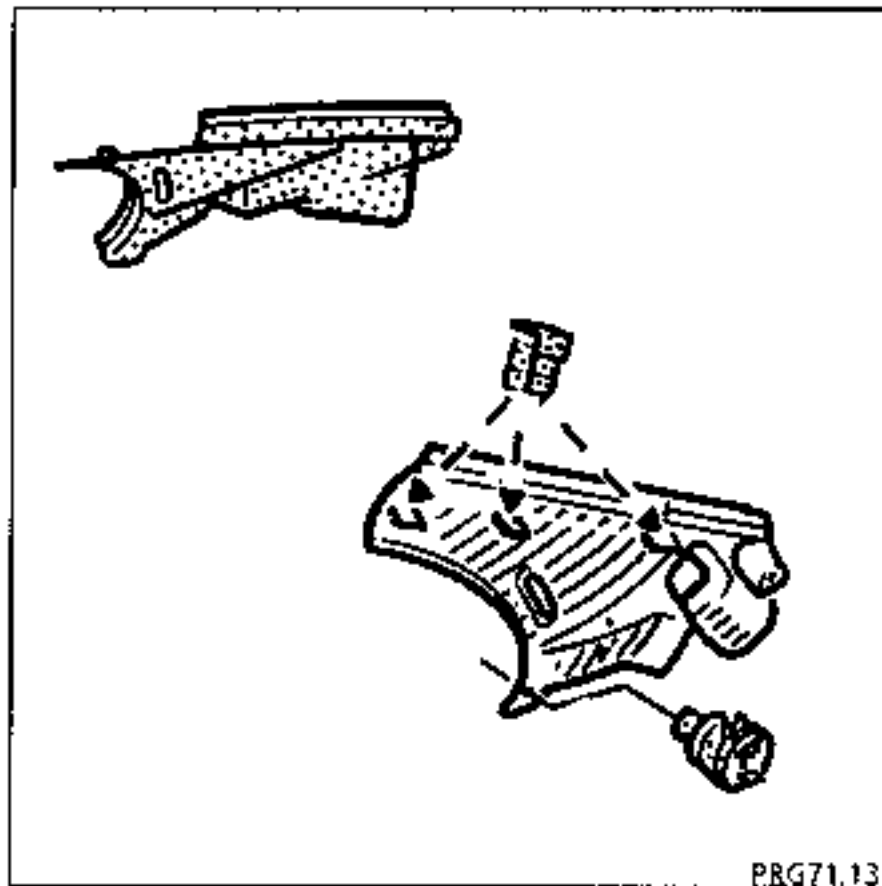

REMOVAL

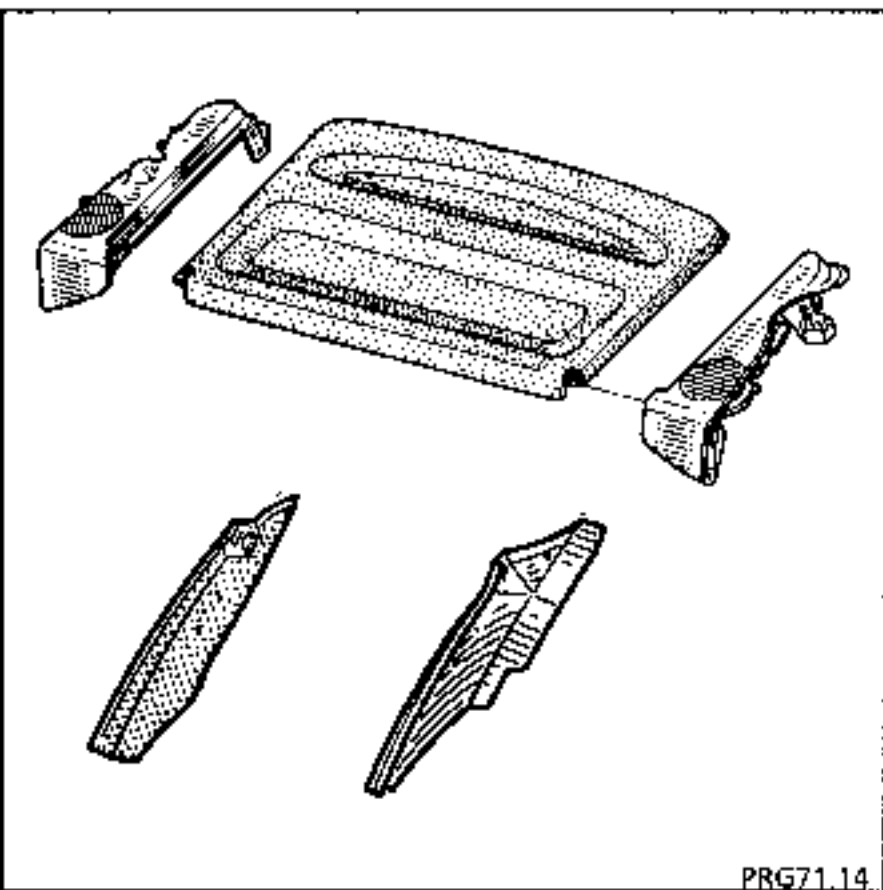

Remove:

- the central and side shelves (see 74A),
- the upper rear valance lining (see 71D),

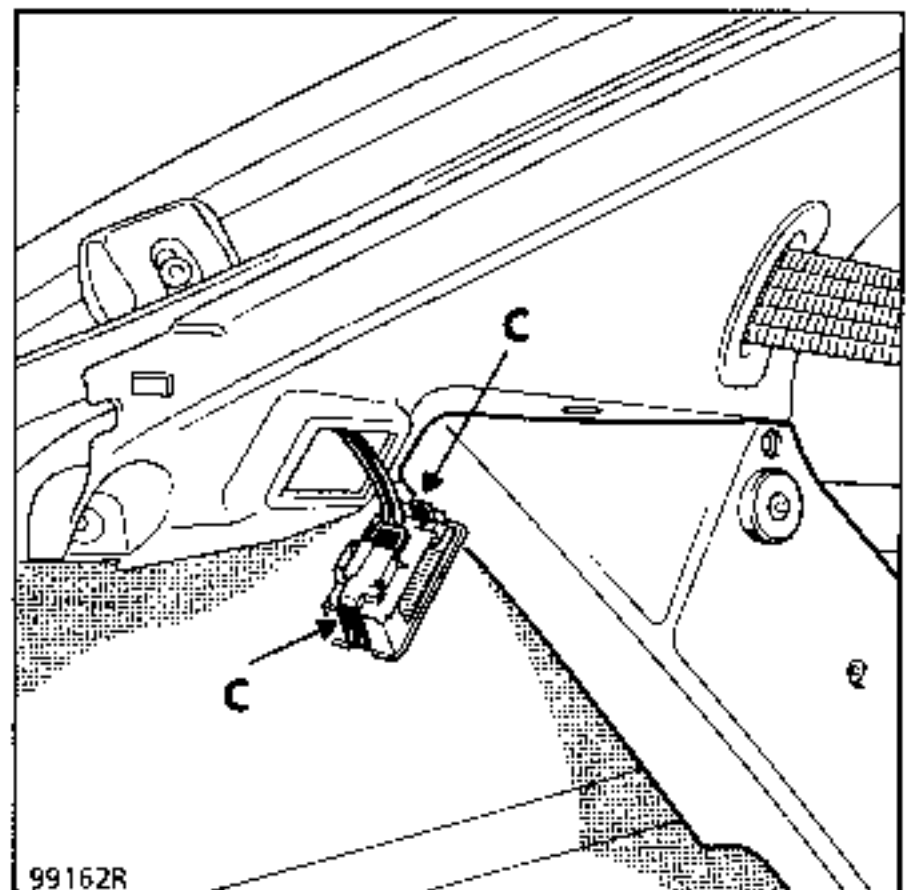

Remove the light from the luggage compartment on the left hand side trim panel by pressing clips (C).

Disconnect the light connector.

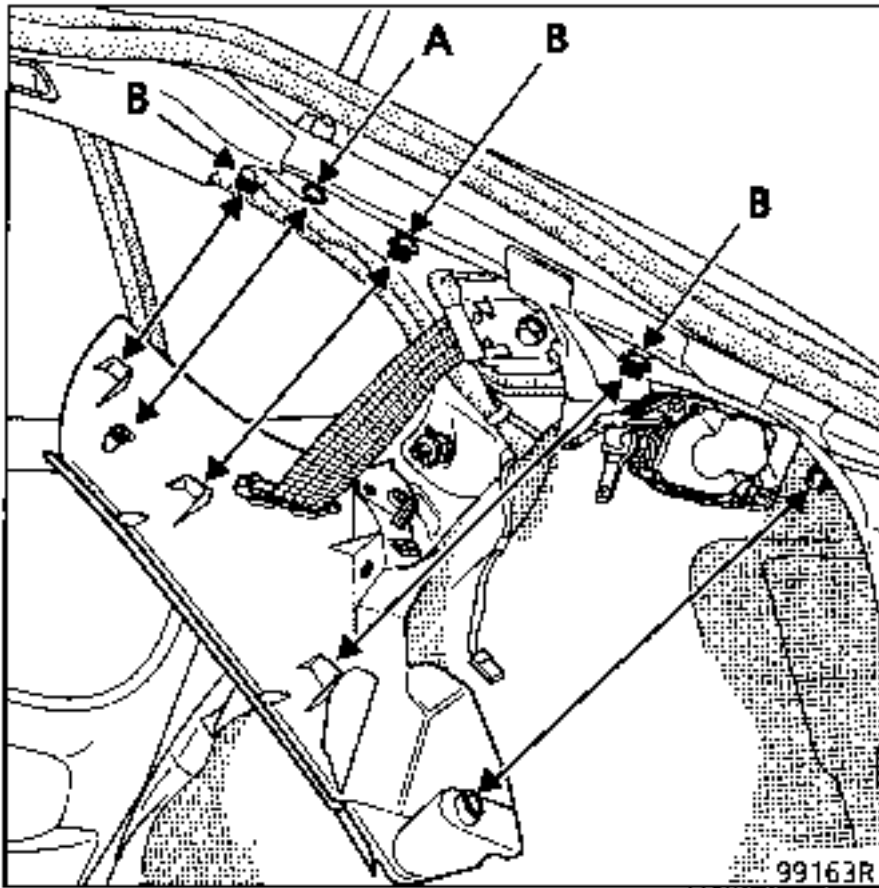

Carefully release clip (A) and separate the lining from the three clips (B).

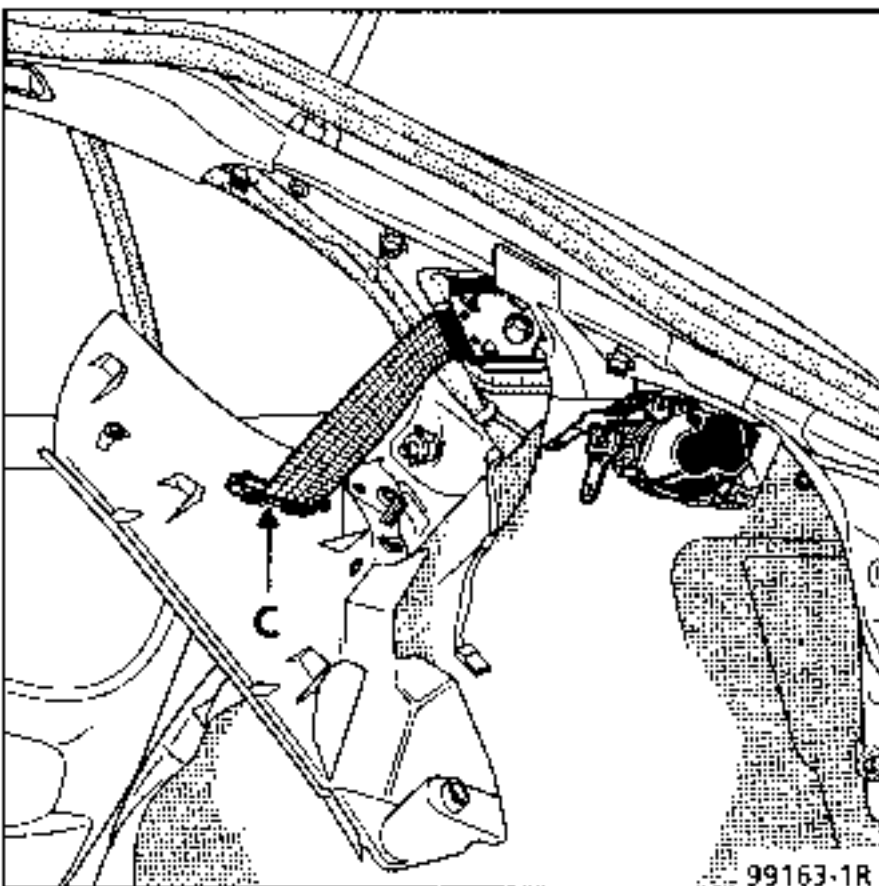

Unclip and remove the inertia reel cover (C) with the lower seat belt mounting so the lining may be removed.

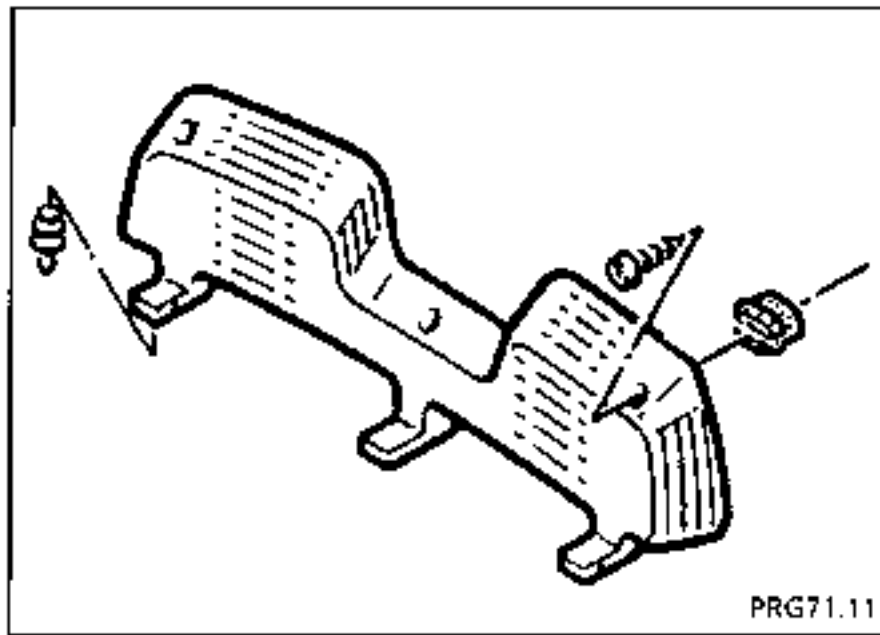

REMOVAL

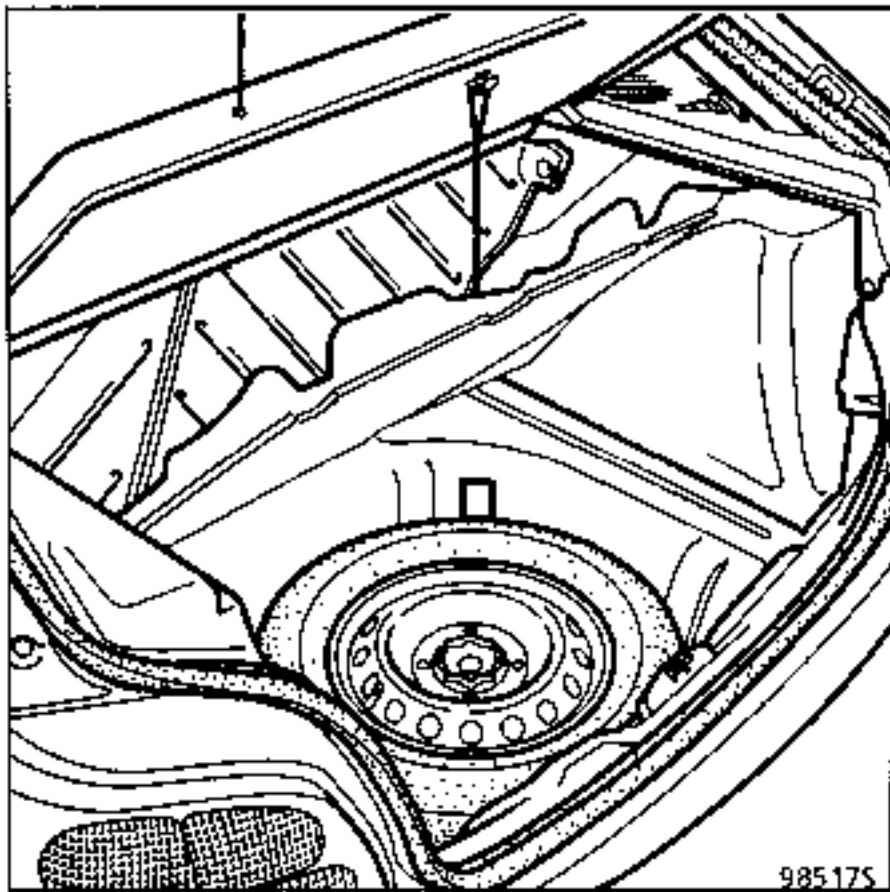

Lift the emergency spare wheel housing cover.

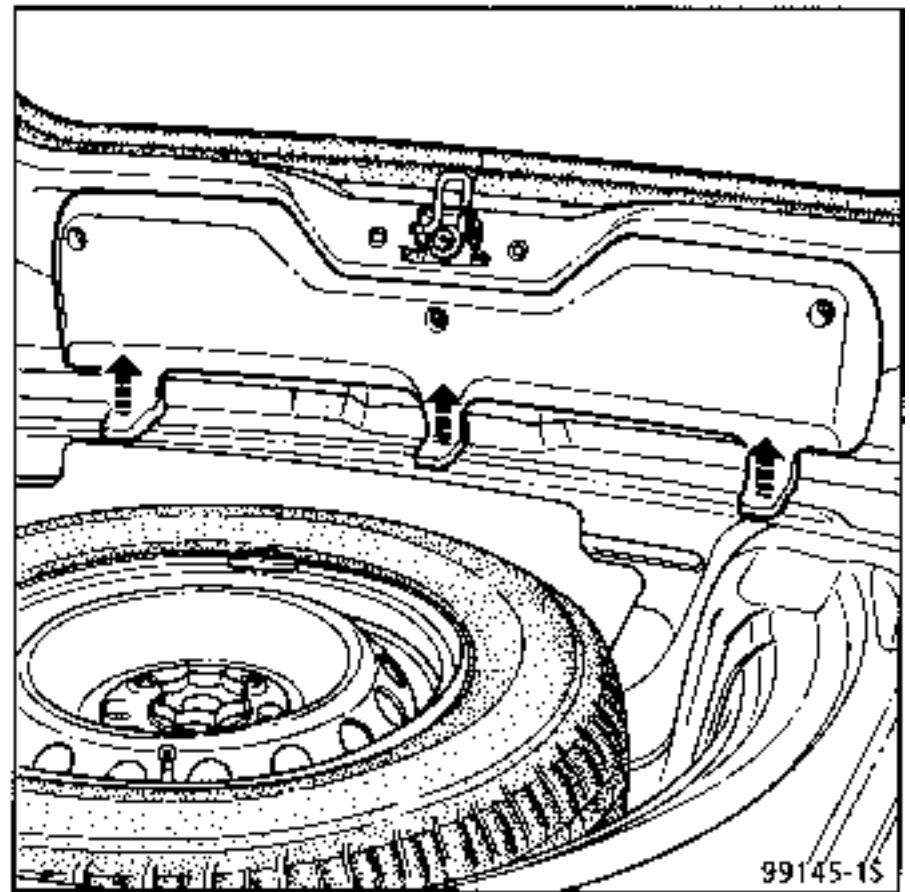

Remove the three mounting bolts (A).

Release the three clips (B) and remove the lining.

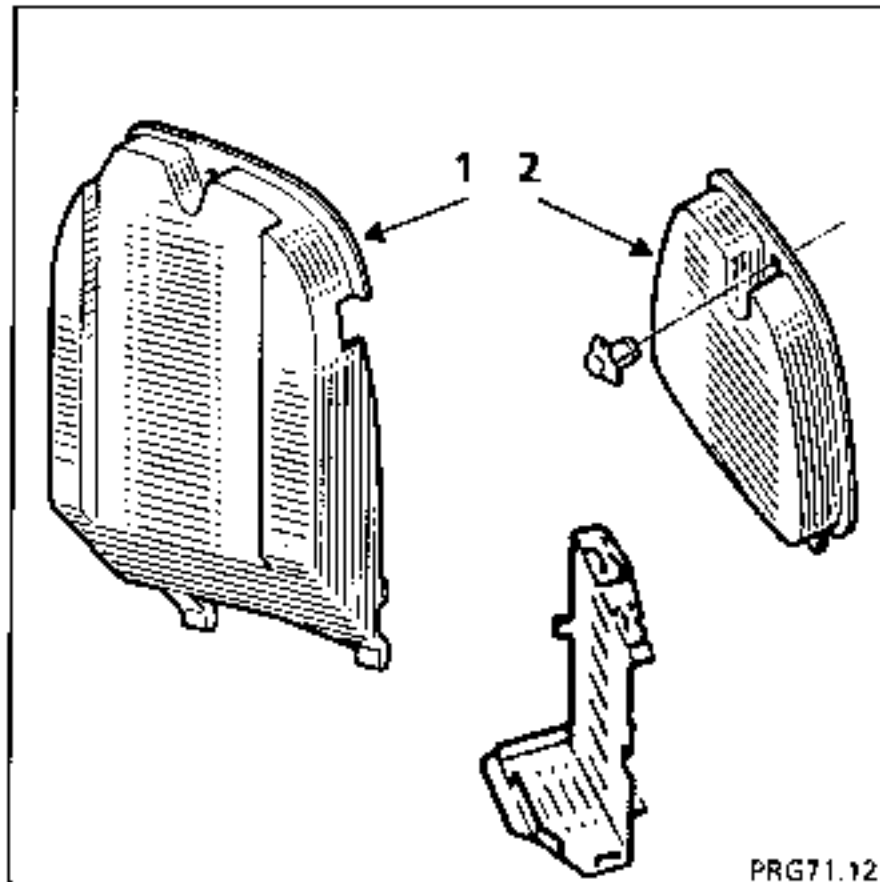

- (1) Rear right hand wing lining.
- (2) Rear left hand wing lining.

### REMOVAL OF RIGHT HAND WING LINING

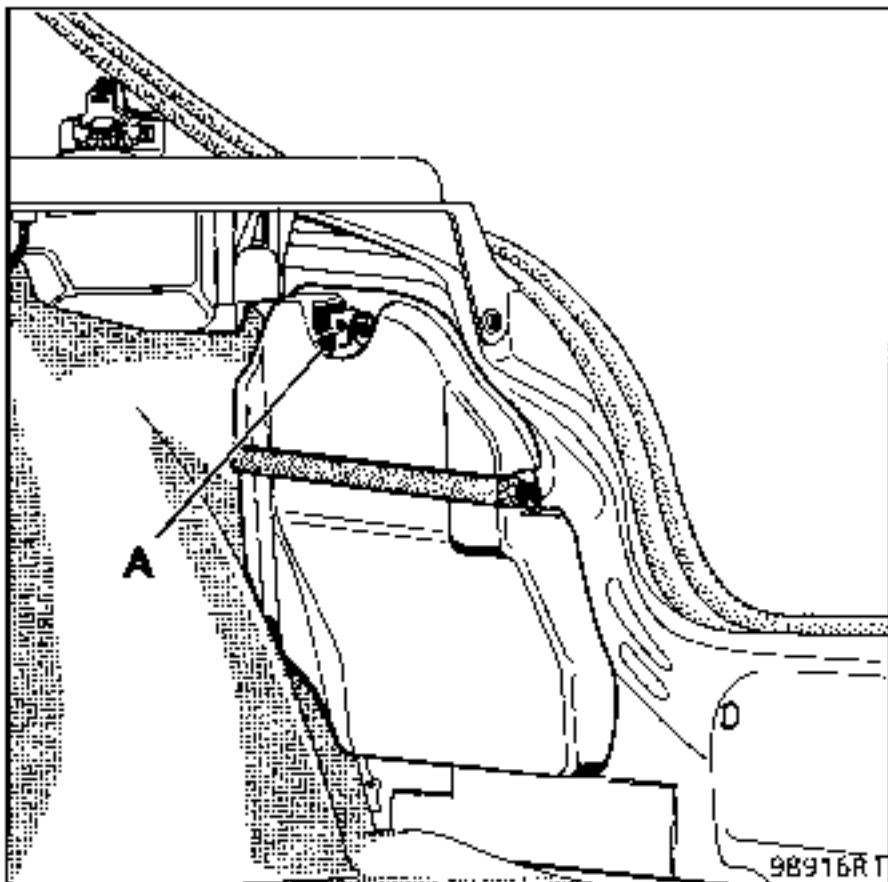

Remove the knob (A).

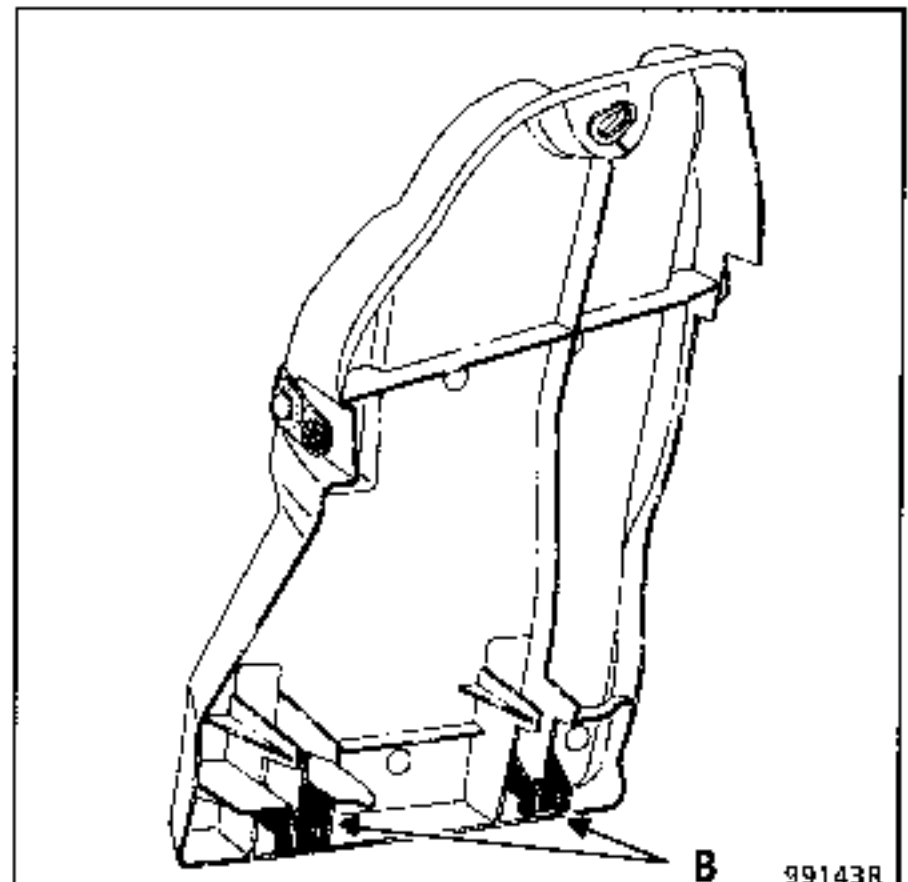

Release the upper section of the lining towards the front of the vehicle.

Pull the lining panel upwards to release the two brackets (B) from the rear lights plate.

### REMOVAL OF LEFT HAND WING LINING

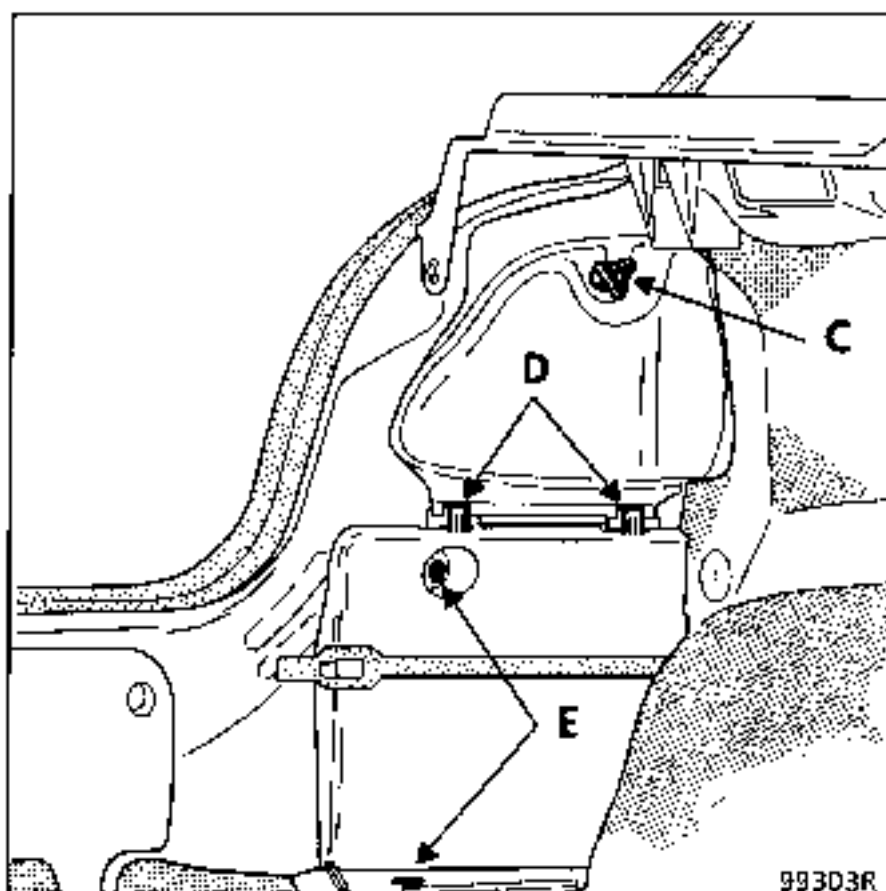

Remove :

- the knob (C) from the left hand rear lights unit inspection cover,
- the inspection cover, releasing the two pins (D) from the lower section of the lining,
- remove the two panel bolts (E).

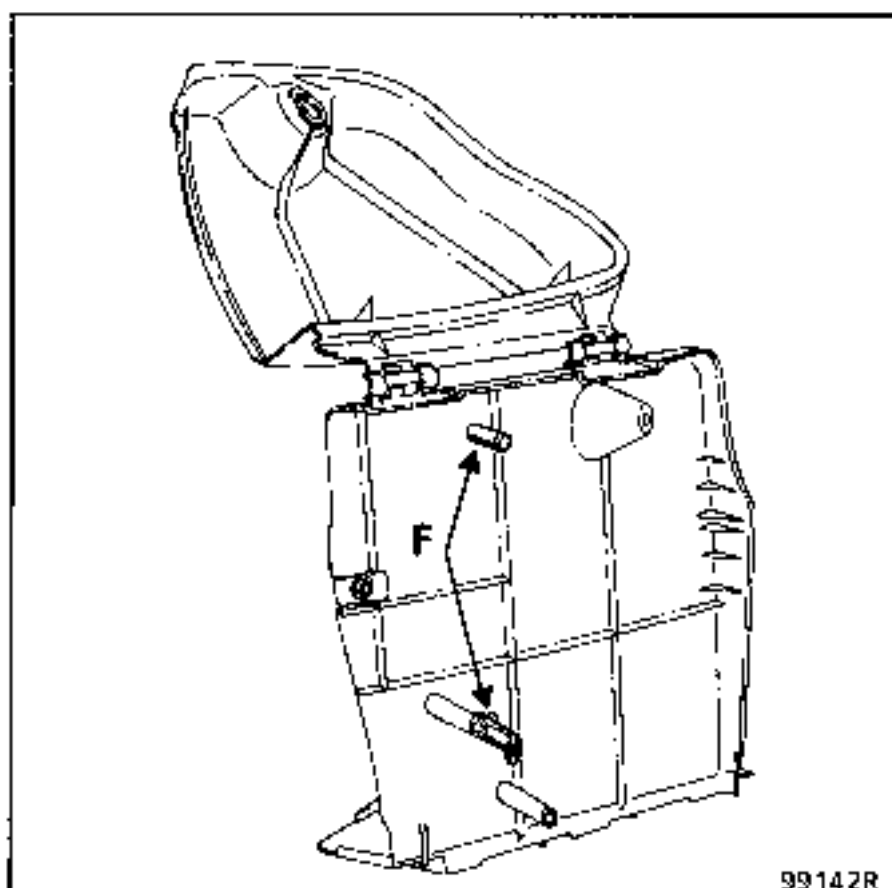



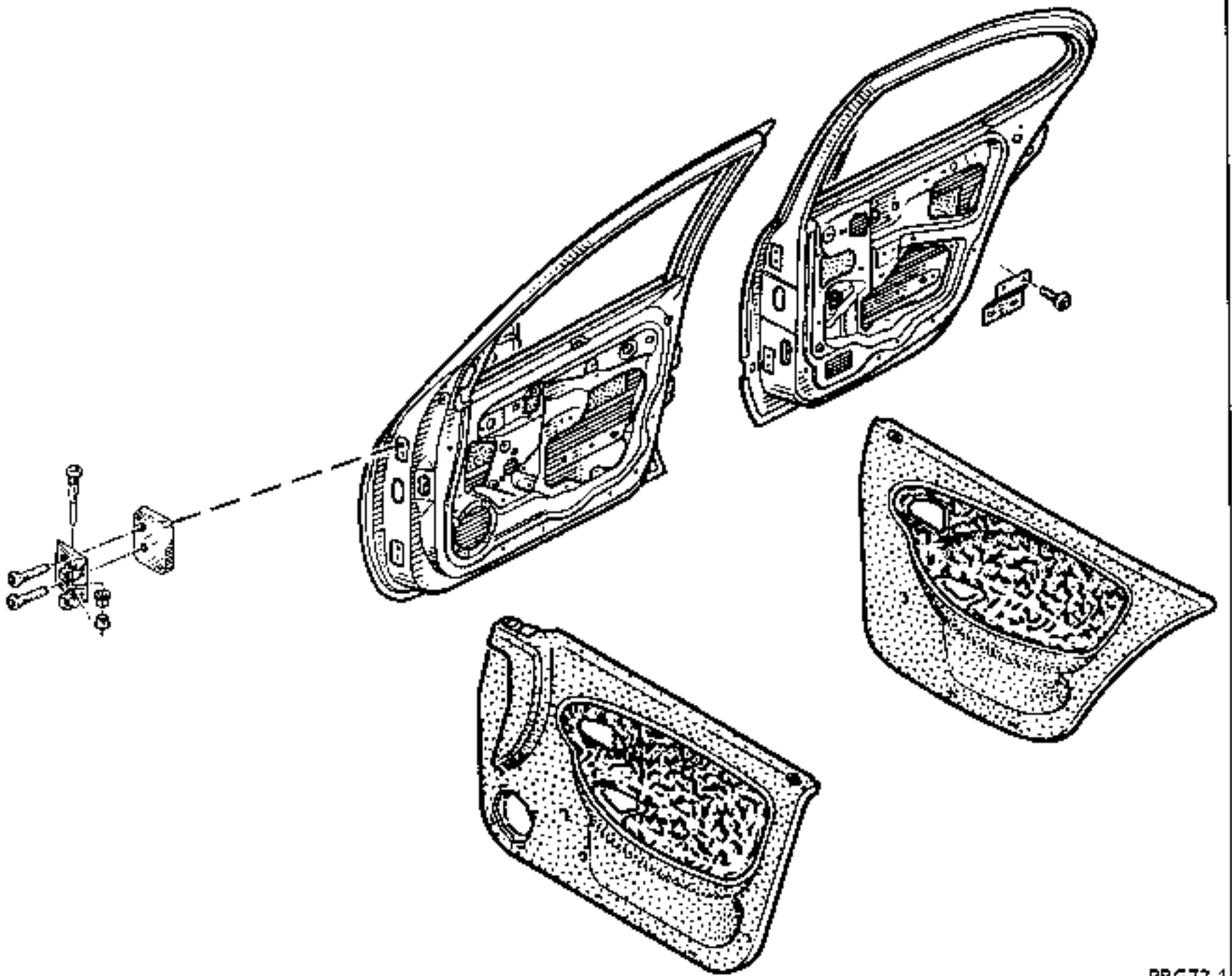





















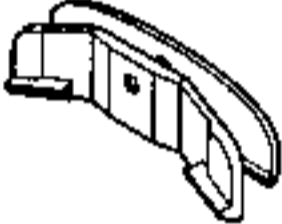









Release the two brackets (F) from the rear lights plate.





The kit shown below is used for refitting front and rear doors and includes all the mountings required.

35 PART NUMBERS - 77 PARTS

 x5	 x1	 x2	 x9	 x8	 x2
 x1	 x1	 x3	 x1	 x1	 x1
 x2	 x5	 x1	 x1	 x3	 x2
 x3	 x1	 x1	 x1	 x1	 x1
 x1	 x2	 x1	 x1	 x1	
 x1	 x1	 x2	 x4	 x4	 x2

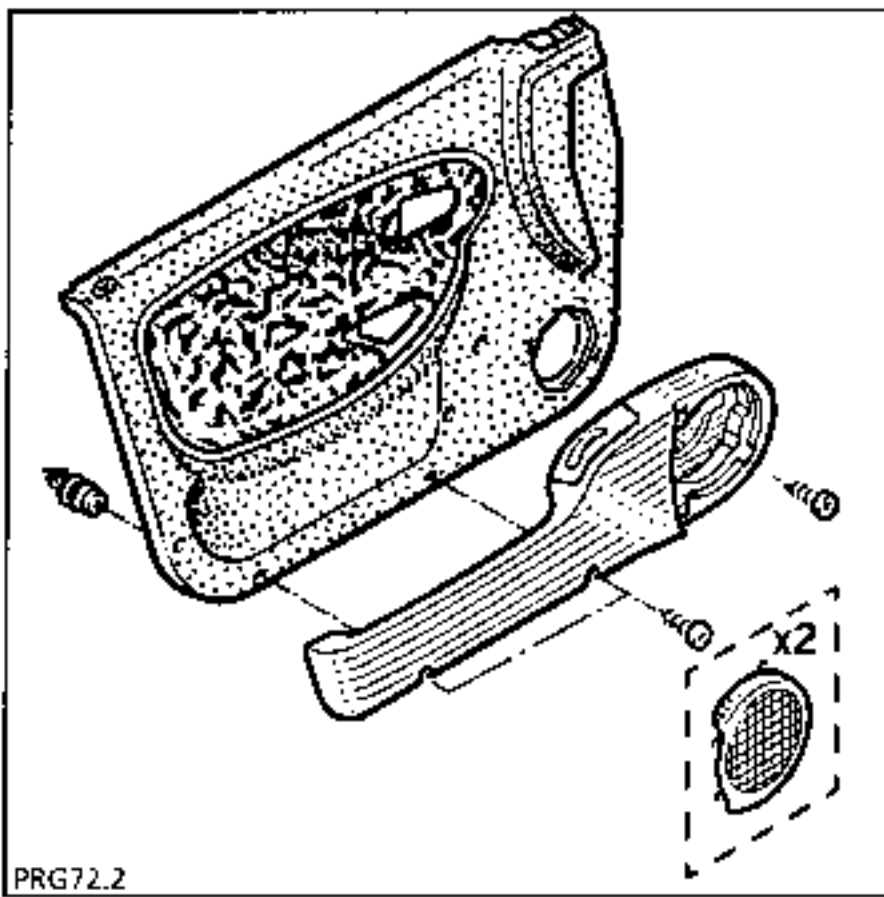

REMOVAL

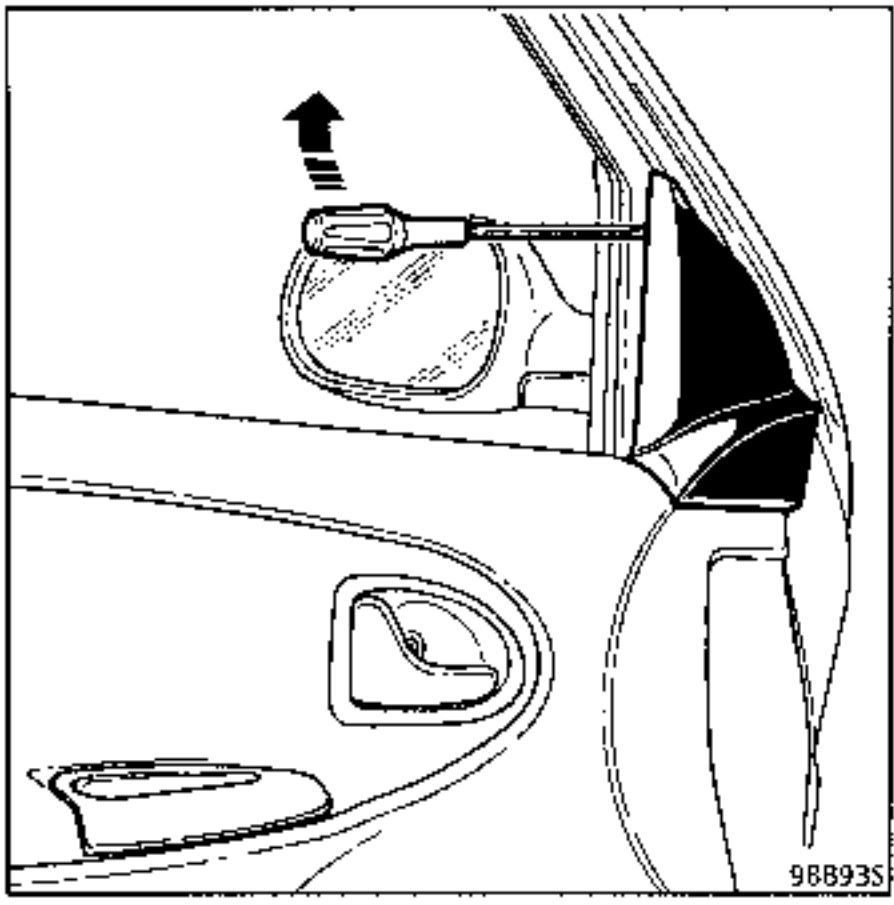

Unclip the rear view mirror mounting cover.

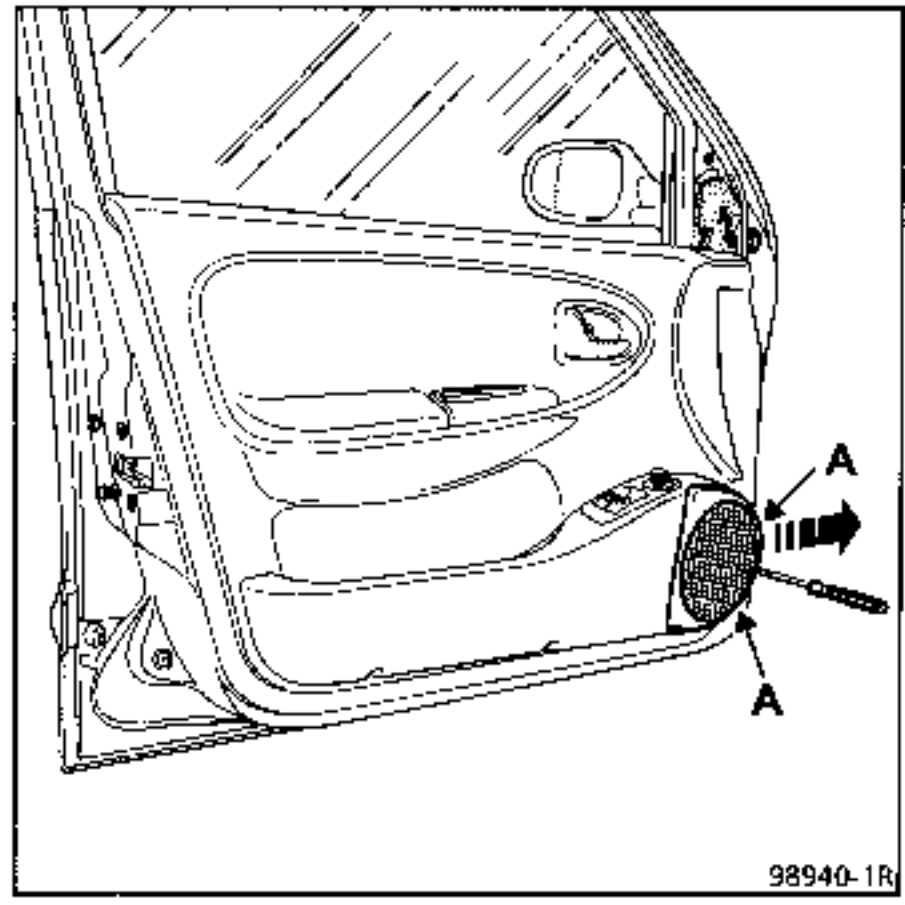

Release the two clips (A) and remove the speaker grille.

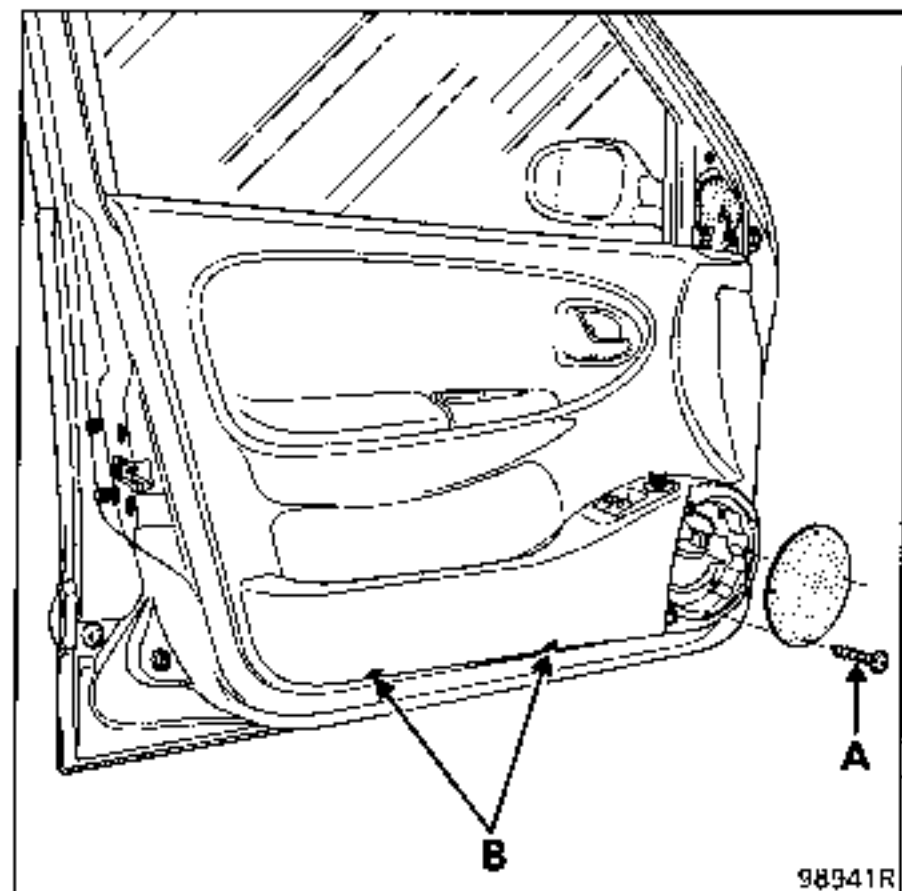

Remove the 8 mounting bolts for the door tray L15 (A) and 2 bolts L25 (B) Torx 20.

Lift the tray to release it from its two locating pins on the door.

Disconnect the connectors.

**When carrying out an operation on the electric window switches, the door tray must be removed.**

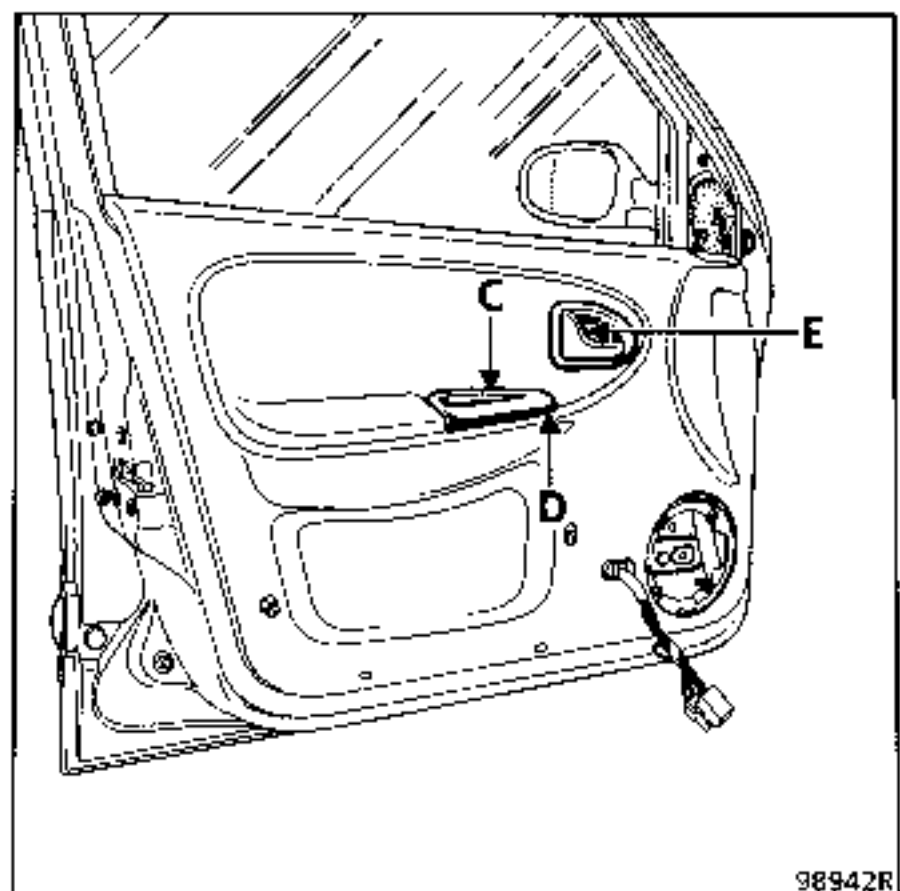

Remove:

- the bolt cover (C) (stick a bead of preformed mastic onto the cover and pull to remove the cover without damaging it),
- the door closing handle (D) Torx bolt 20,
- the door opening handle (E) Torx bolt 30.

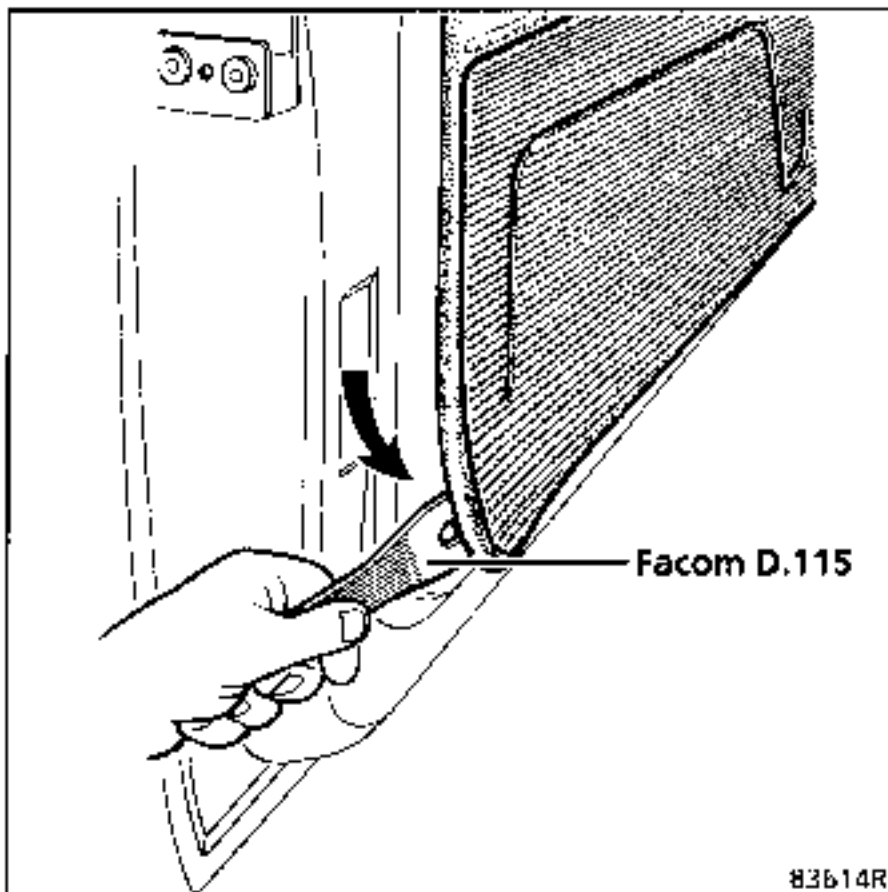

Remove the mountings using a tool of type Facom D.115.  
Unclip and release the trim panel as you go along (use a sharp knife to cut the mastic).

**NOTE :** an unpicking tool may also be used (see 50B), which facilitates this operation.

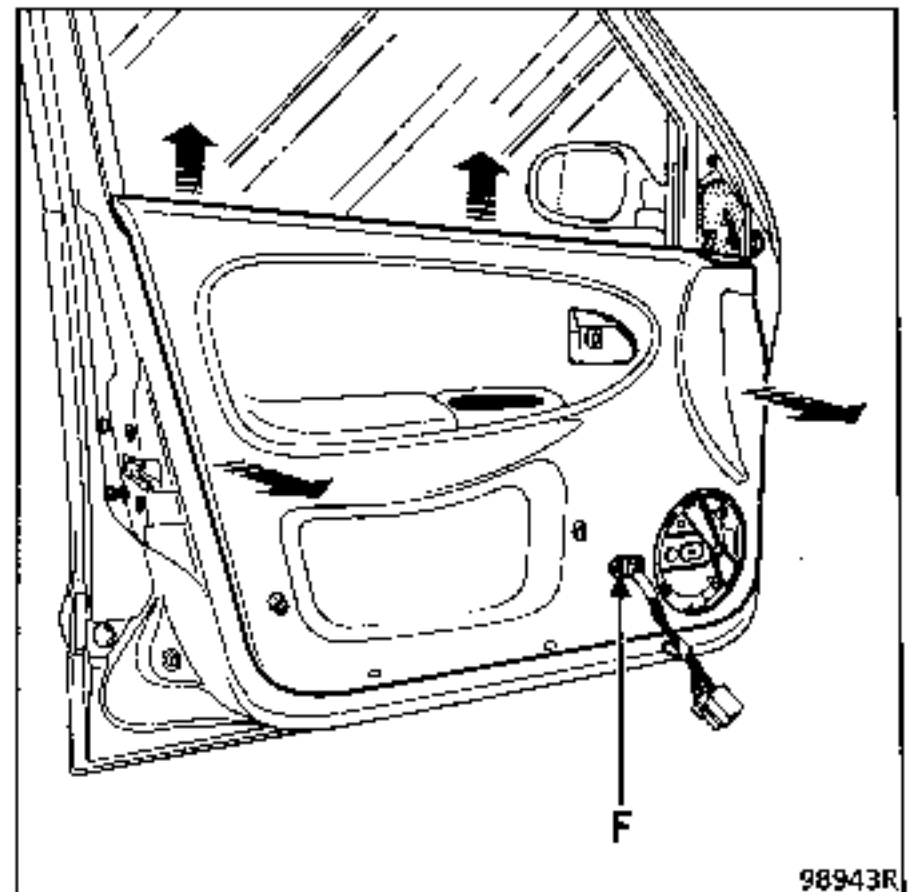

Remove the trim panel from its location on the inner weather strip of the front door.  
Release blanking plug (F) to permit the connectors at the bottom of the trim panel to be passed through.  
Remove the trim panel.

Ensure no adhesive foam for the rear view mirror wiring comes into contact with the location where the door seal is fitted.

When removing or replacing the panel, preformed sealing mastic **MUST** be used (Part Number : 77 01 423 330).

When replacing a door, we recommend that the door kit be used (see 72A) which includes all the door mountings required for fitting trim to a new door.

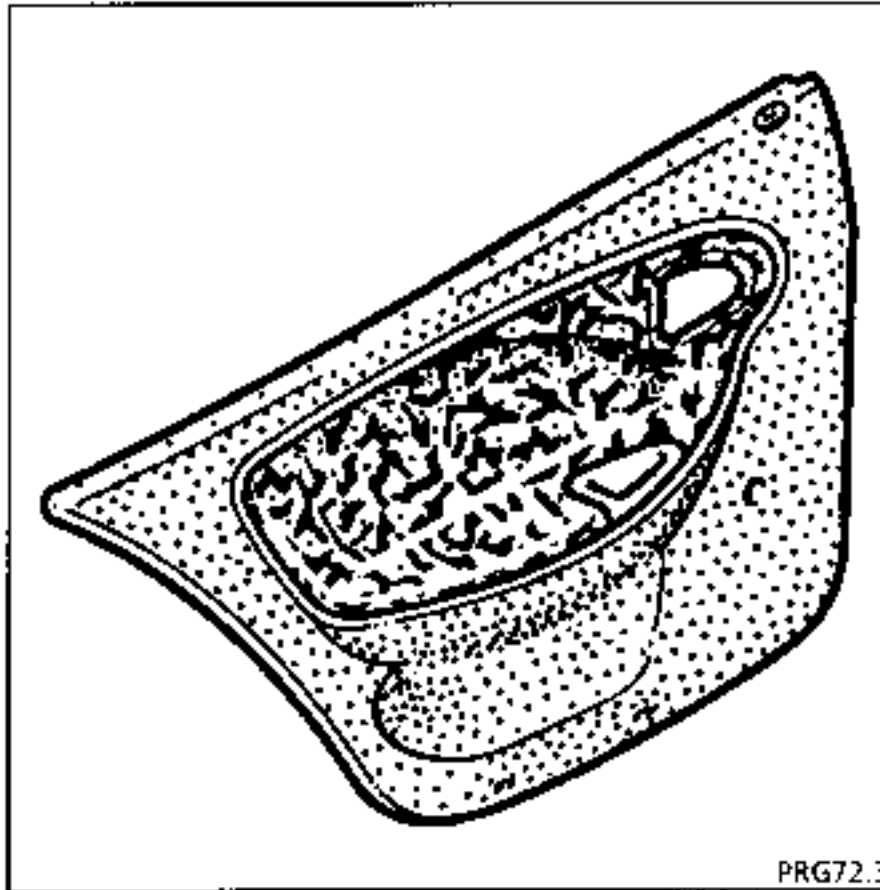

REMOVAL

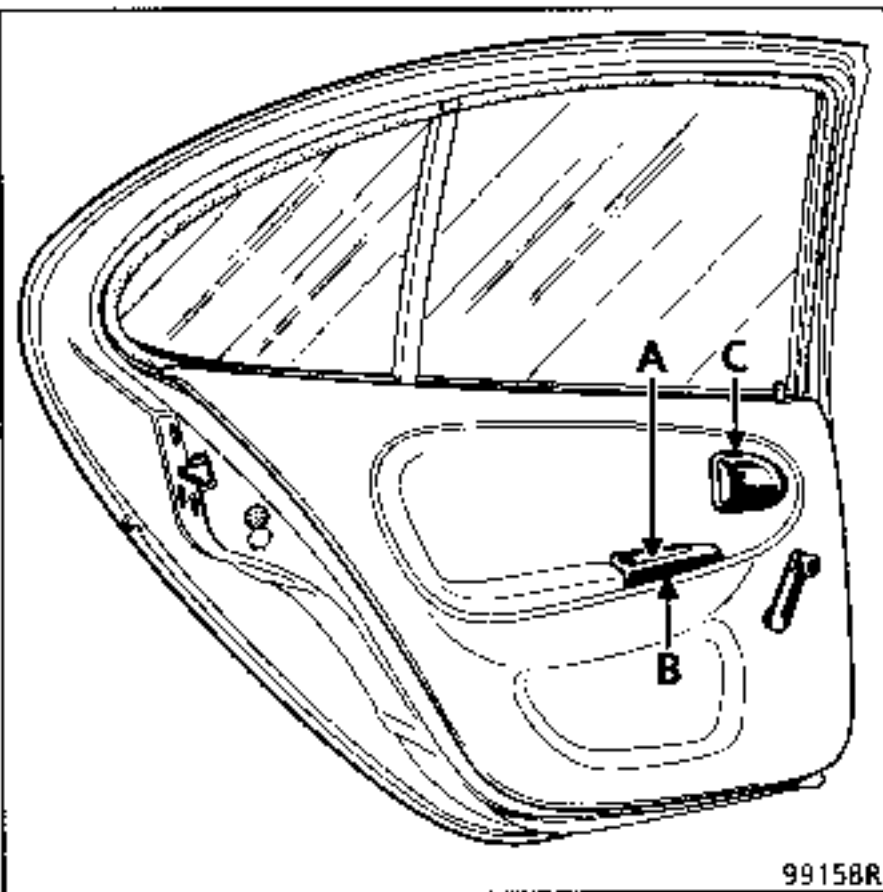

Remove:

- the bolt cover (A) (stick a bead of preformed mastic onto the cover and pull to remove the cover without damaging it),
- the door closing handle (B) Torx bolt 20 and pull the handle upwards to release it from the trim panel,
- the door opening handle (C) Torx bolt 30 (see 51B),
- the window winder handle (see 51A).

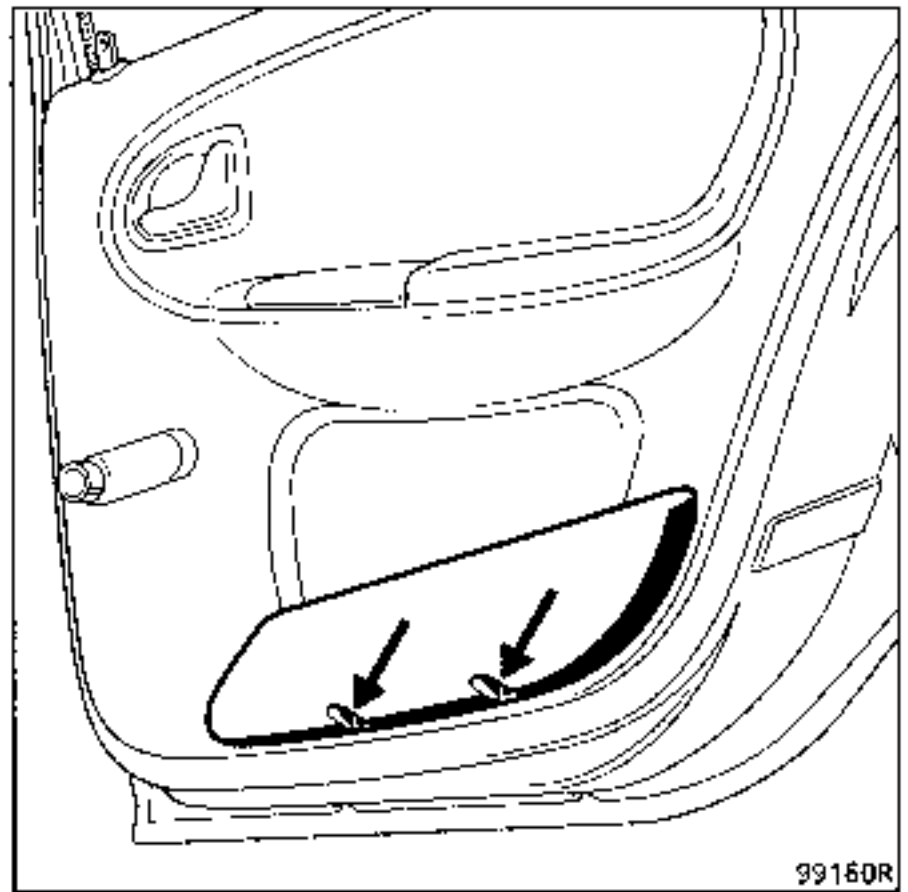

On the rear door, remove the two bolts mounting the door tray, Torx 20.

**IMPORTANT:** the door tray is an integral part of the trim panel. It is removed with the trim panel.

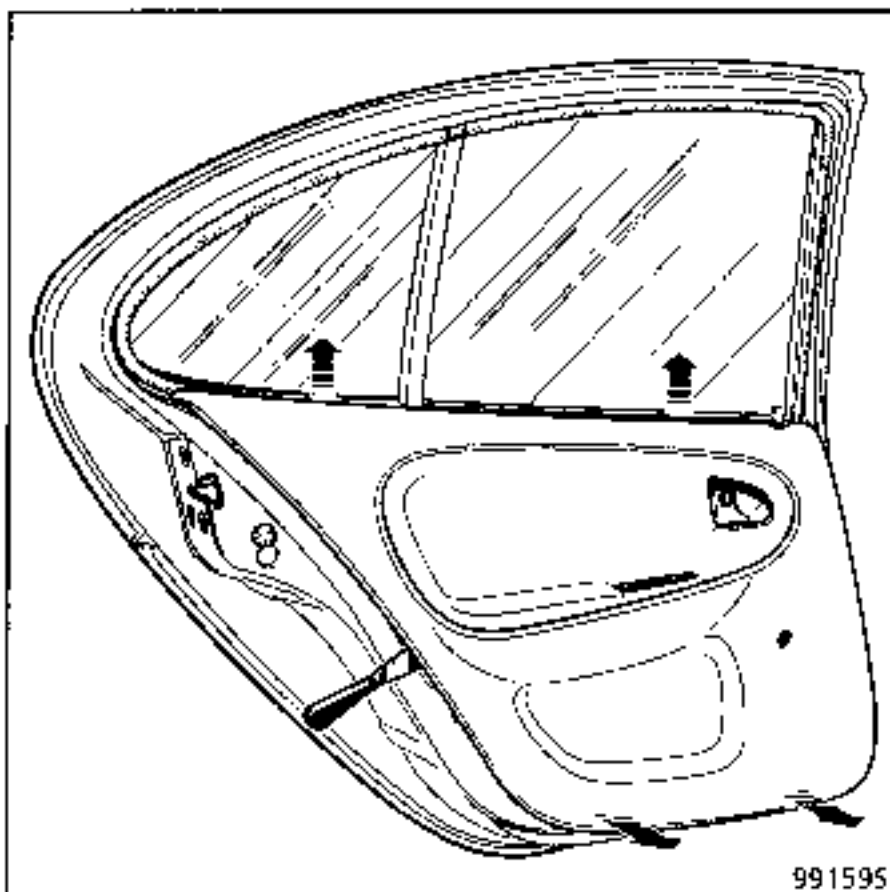

Unclip and release the trim panel as you go along (use a sharp knife to cut the mastic).  
Remove the panel from its location on the inner weatherstrip on the rear door.  
Remove the trim panel.

REPOSE

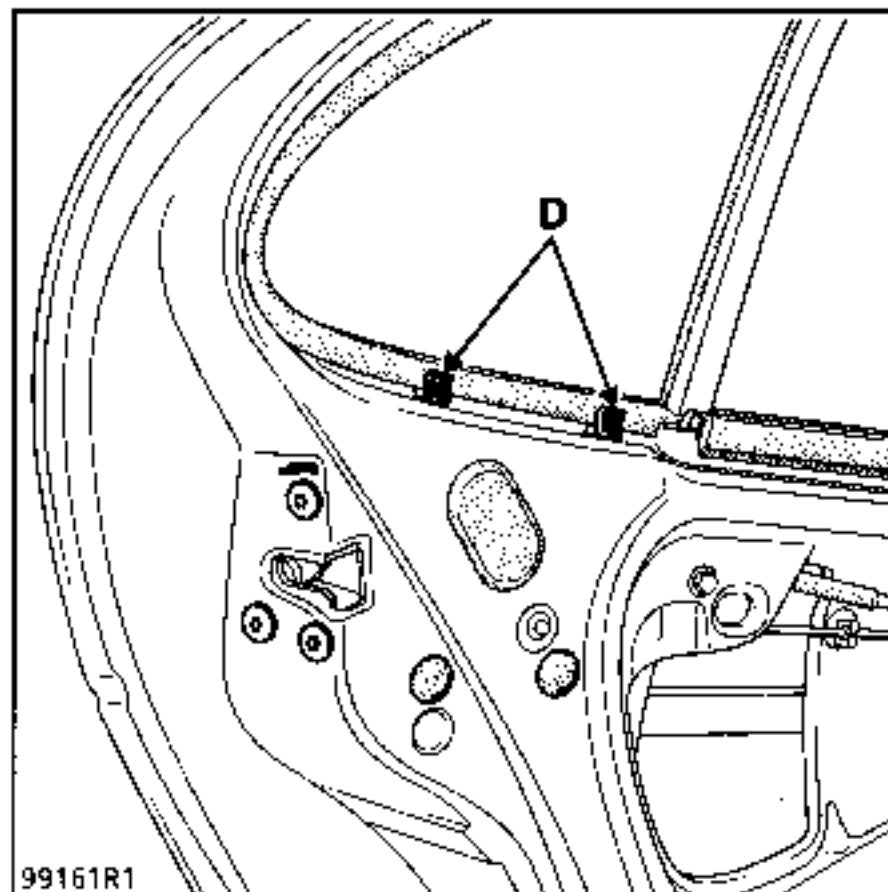

When refitting the trim panel, insert the upper section into the inner weatherstrip on the rear door and also into the two retaining clips (D) under the fixed window.

When removing or replacing the panel, preformed sealing mastic **MUST** be used (Part Number : 77 01 423 330).

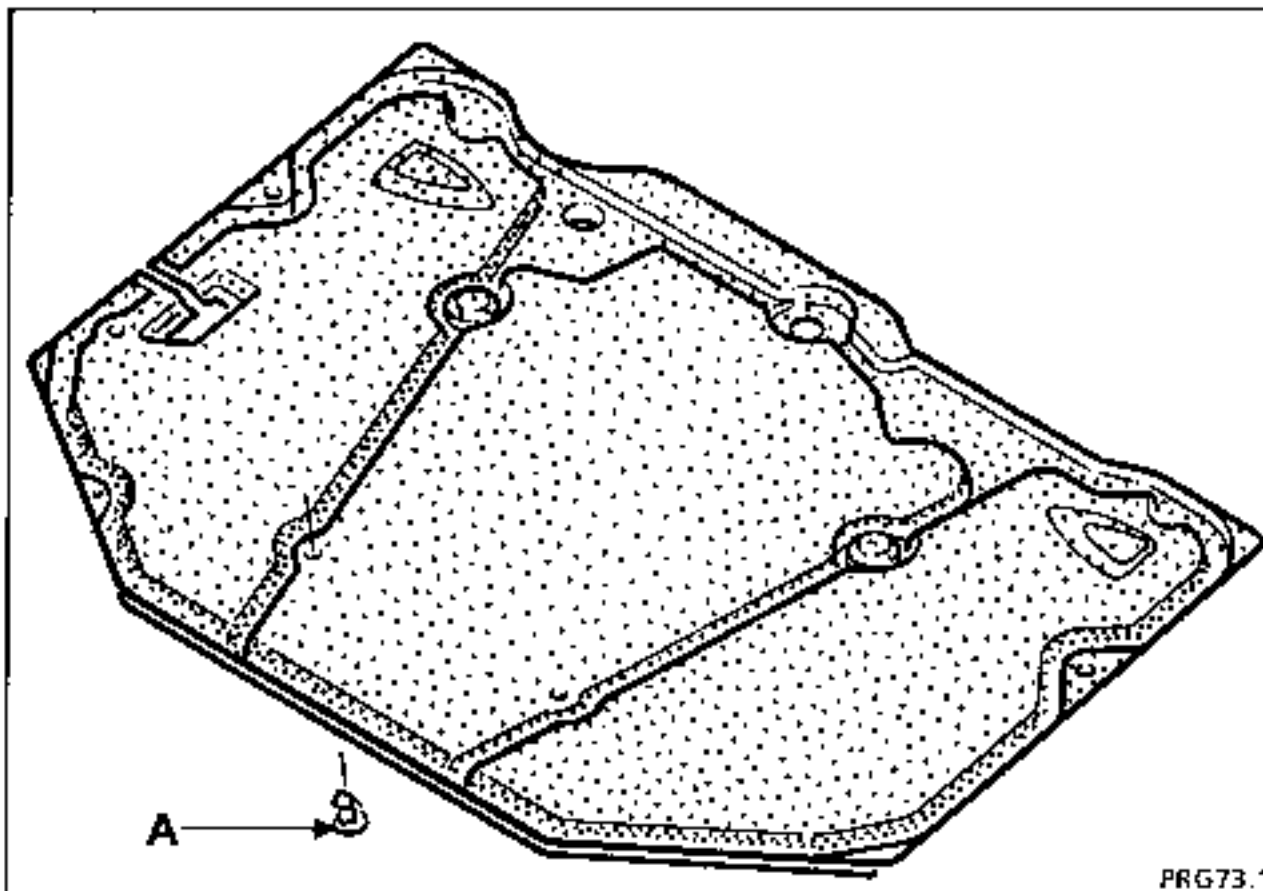

PRG73.1

**REMOVAL**

Unclip the plastic clips (A).

**Tailgate trim**

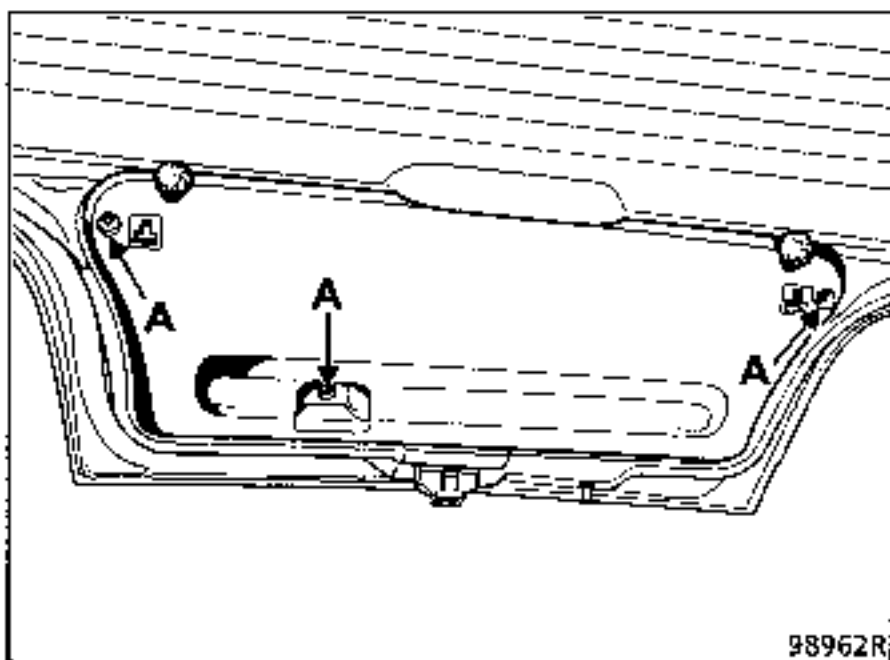

98962R

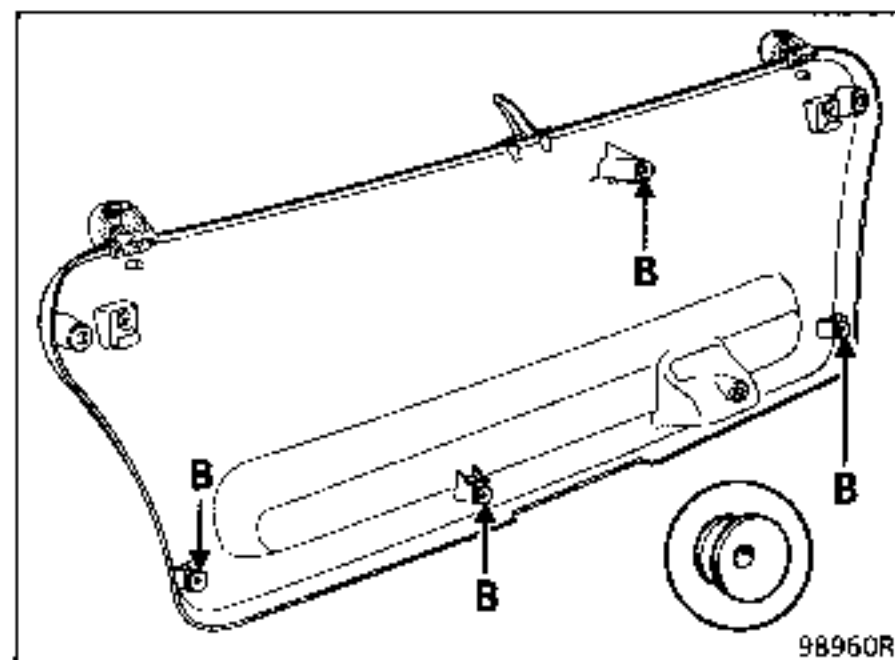

98960R

Remove the three mountings (A).  
Release clips (B) to remove the trim panel.

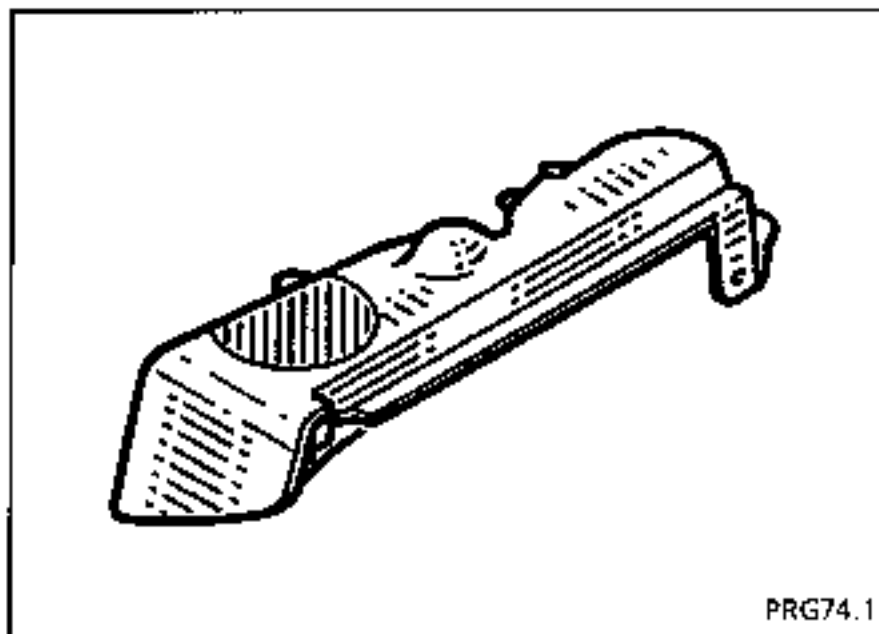

**REMOVAL**

**REFITTING**

When refitting, take care to ensure that on the right hand side, the third rear seat belt is on top of the shelf, not underneath it.

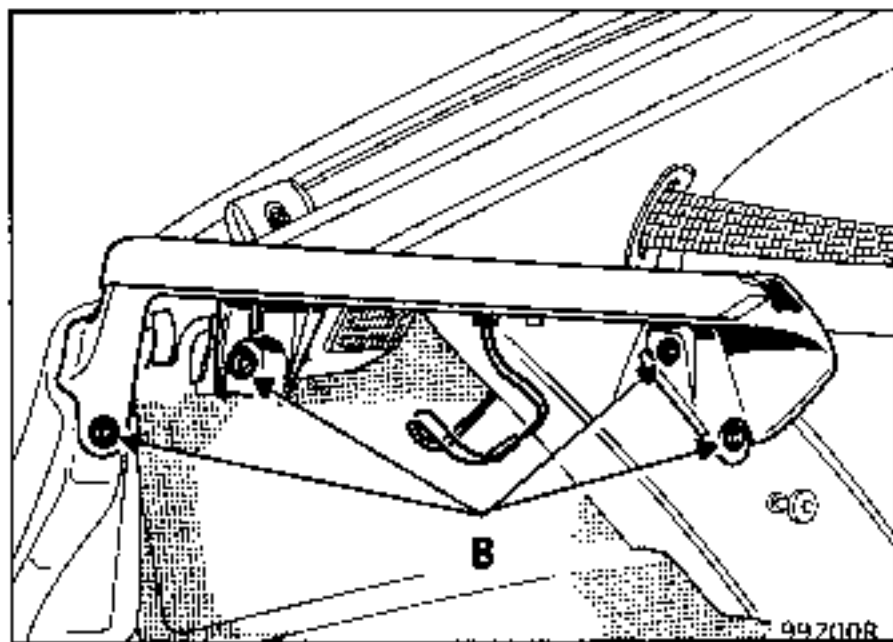

- Remove
- partially, the tailgate seal,
  - the central rear shelf.

Fold the rear seats down.  
Disconnect the speaker connector.  
Remove the four bolts (B) (Torx 20).



**REMOVAL**

Put the vehicle on a lift.

Remove the four mountings under the body.

Disconnect the various connectors (depending on option).

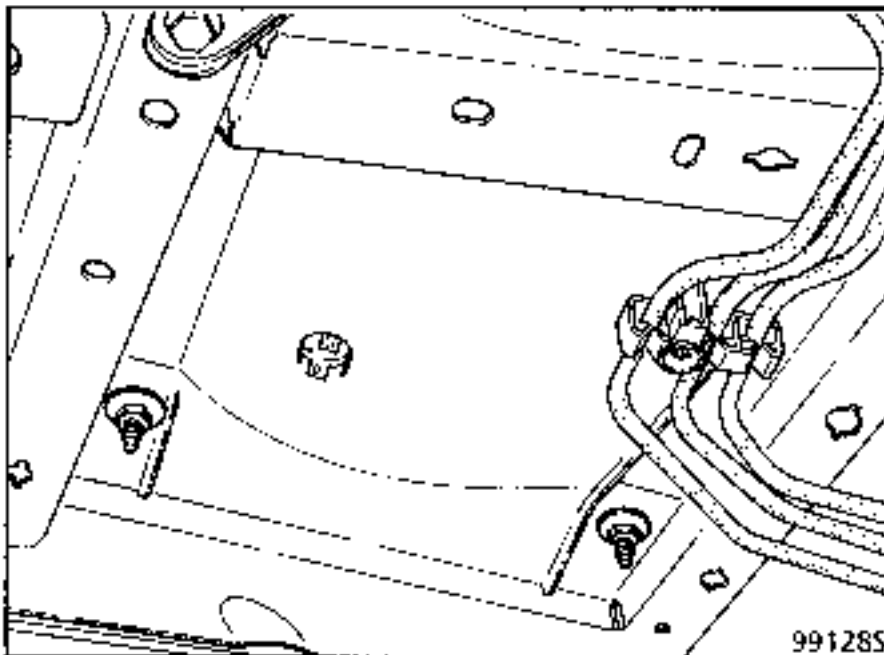



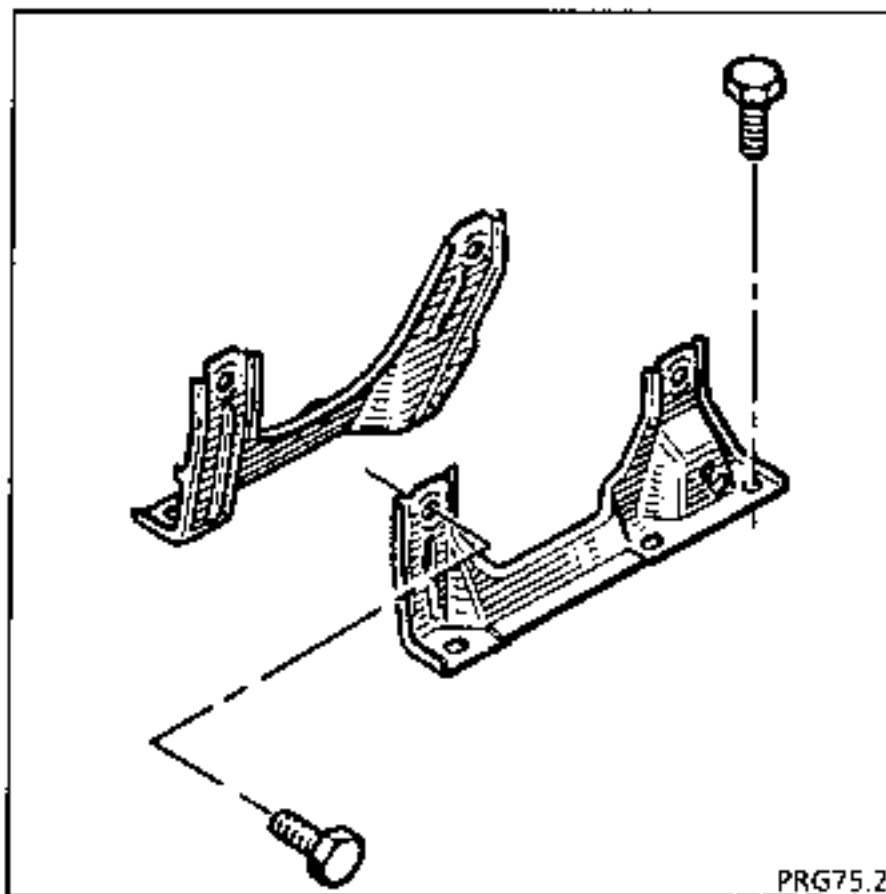

REMOVAL

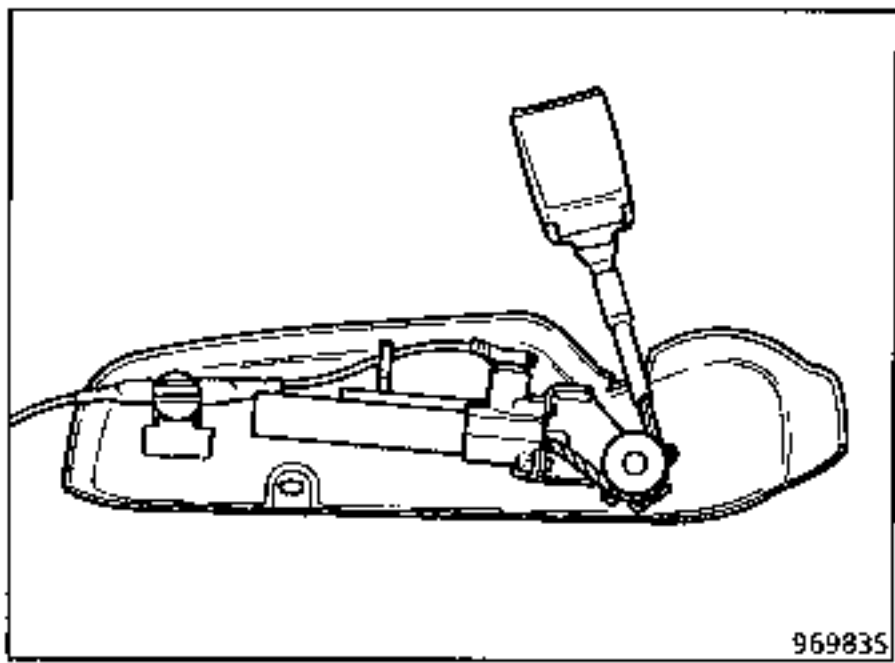
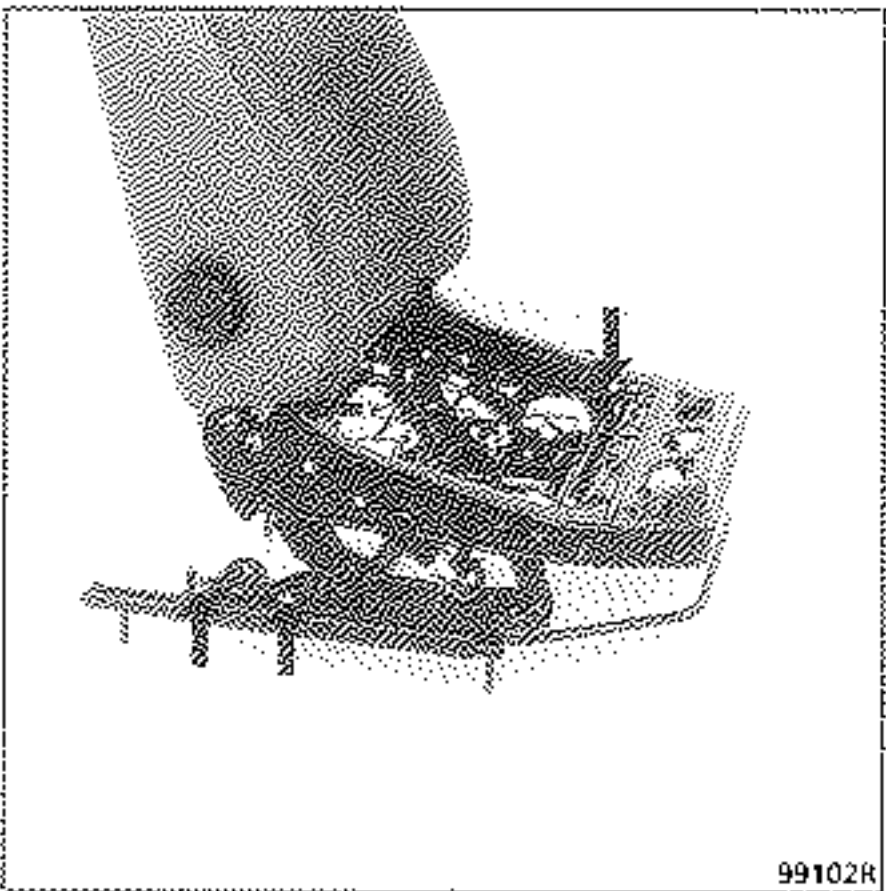

**IMPORTANT:**  
for precautions which must be observed when removing the raising mechanism when pretensioners are fitted refer to the AIRBAG section.

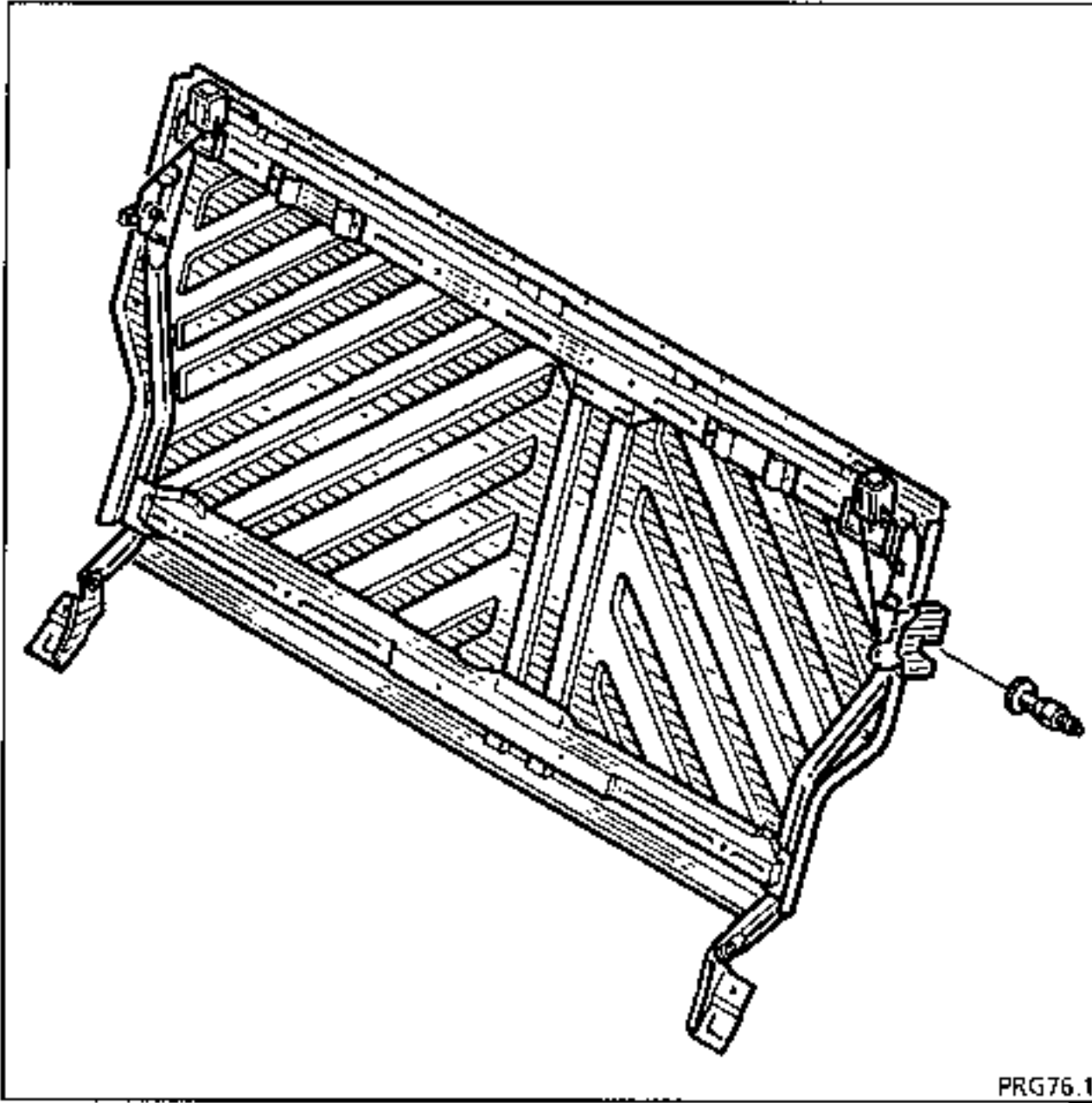

REMOVAL

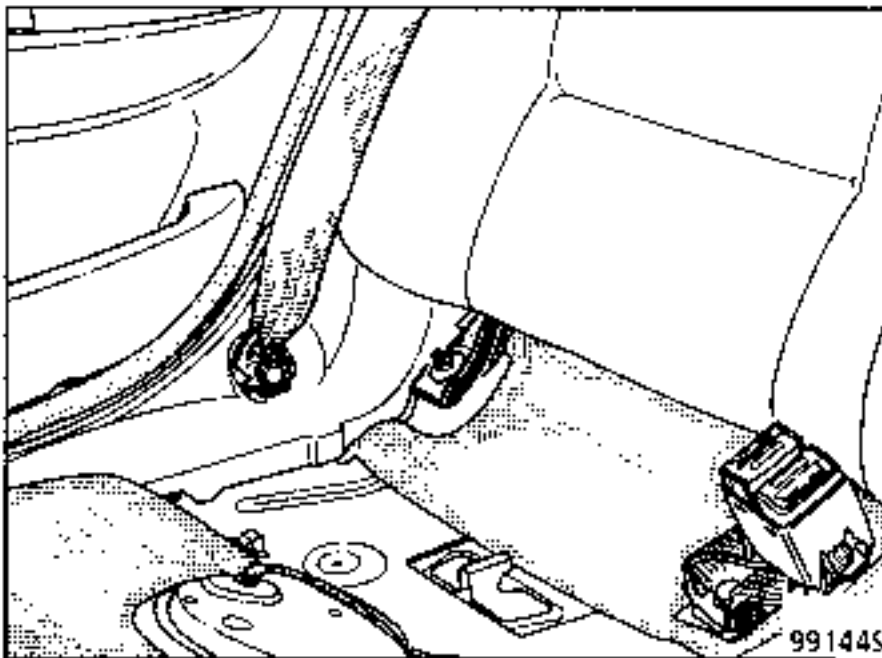

Tilt the seat squabs and remove the three mounting nuts from the seatback.

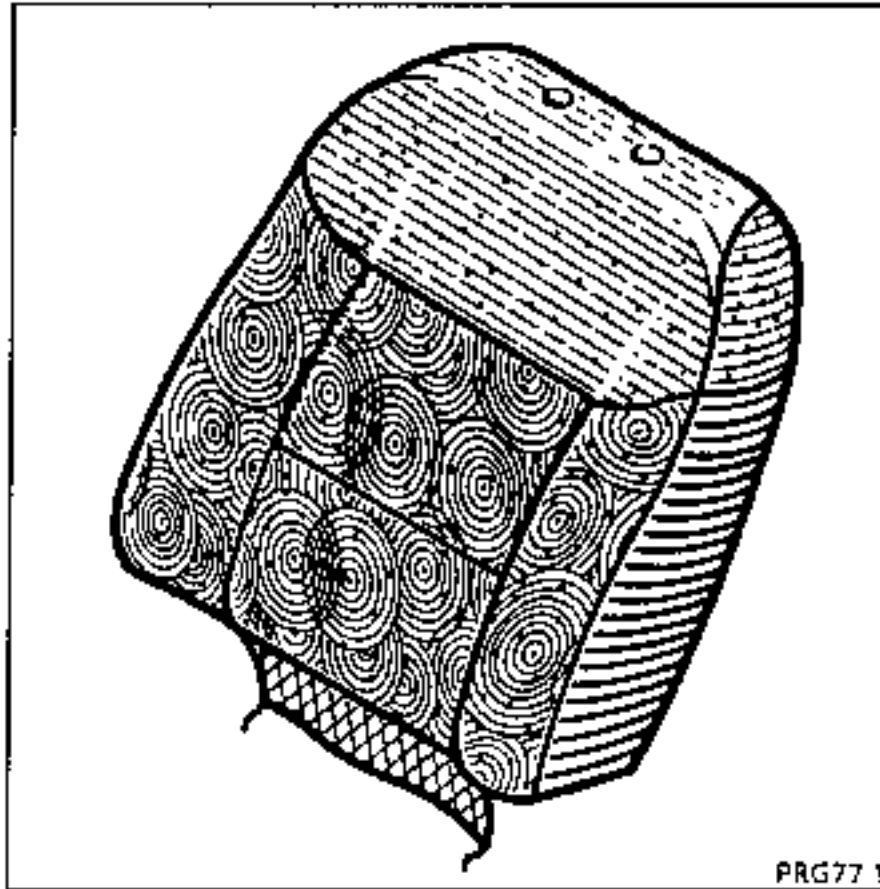

**REMOVAL**

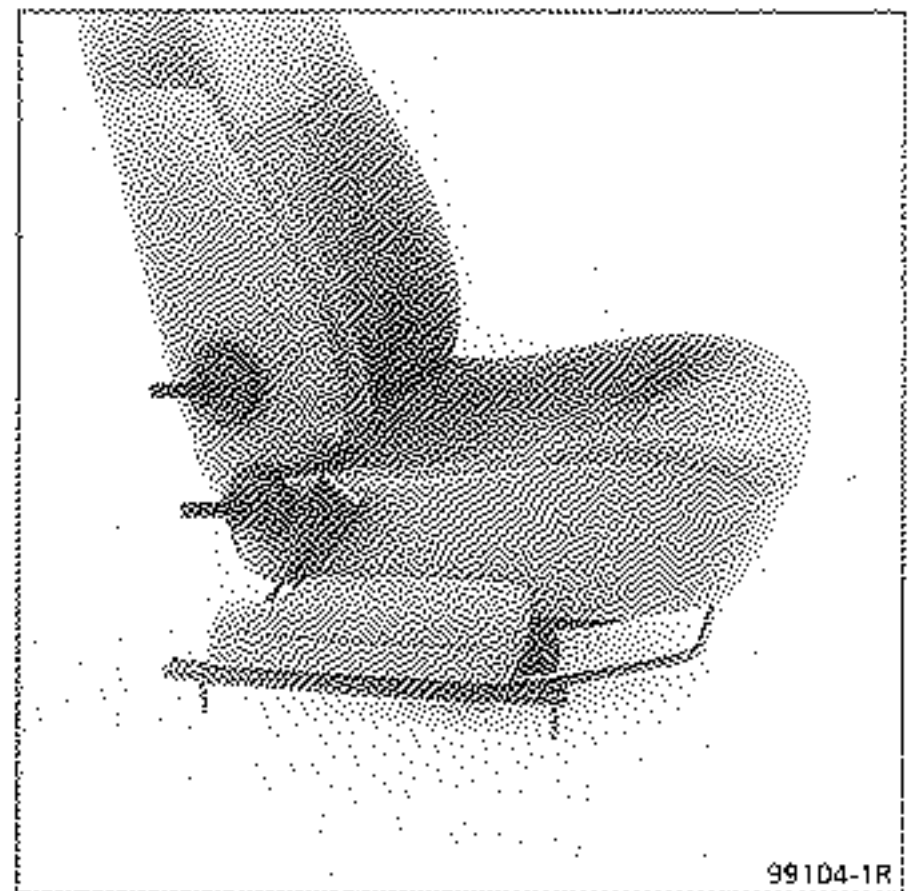
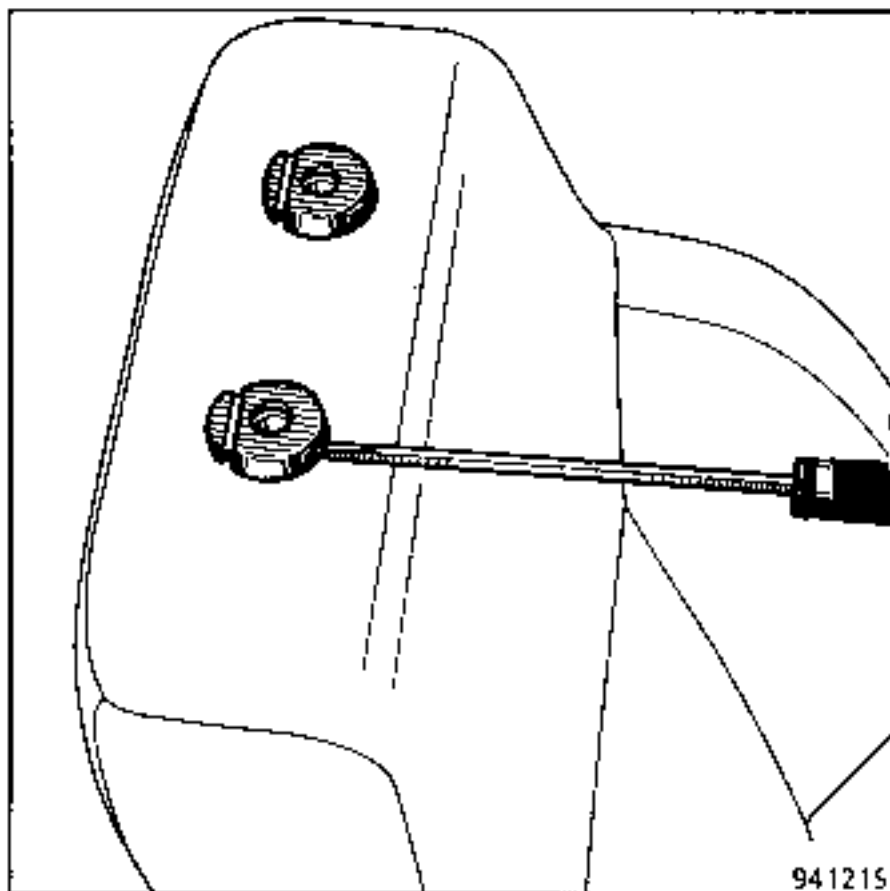

Remove the seat mountings.

Disconnect the wiring connectors.

Remove the head restraint and the upper parts of the head restraint guide.

Remove the central cover from the lumbar adjustment wheel then remove the wheel.

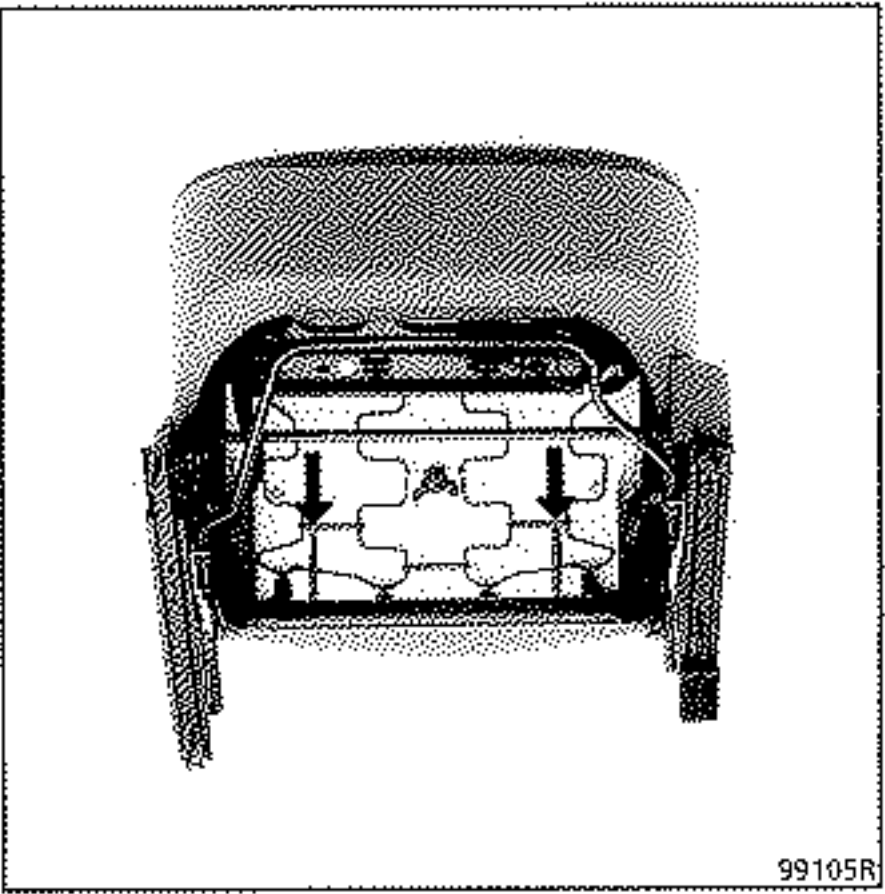

99105R

Cut the clips on the two foam sections under the seat squab.

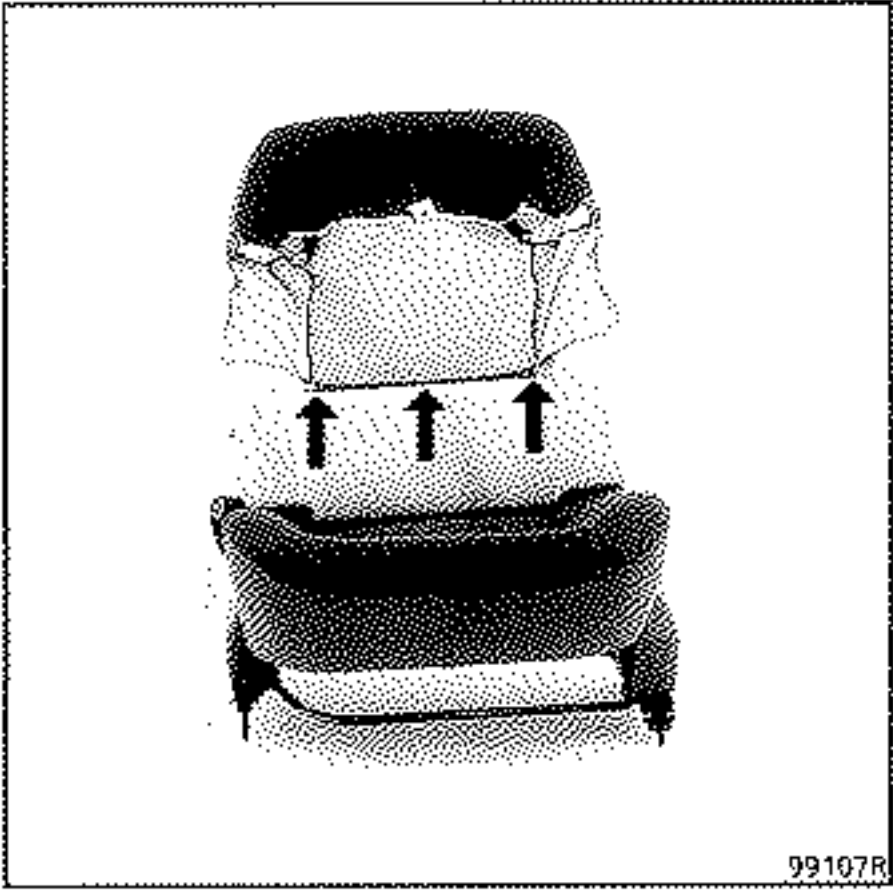

99107R

Turn the trim over and cut the three clips.

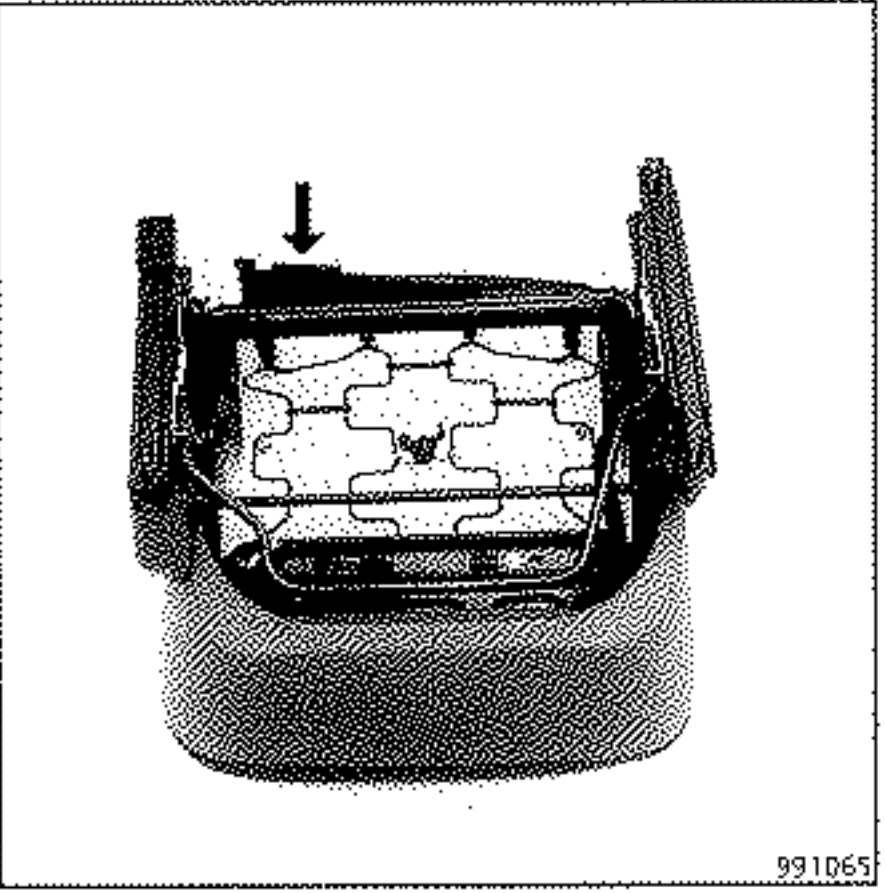

99106S

Unclip the rear edge of the trim.

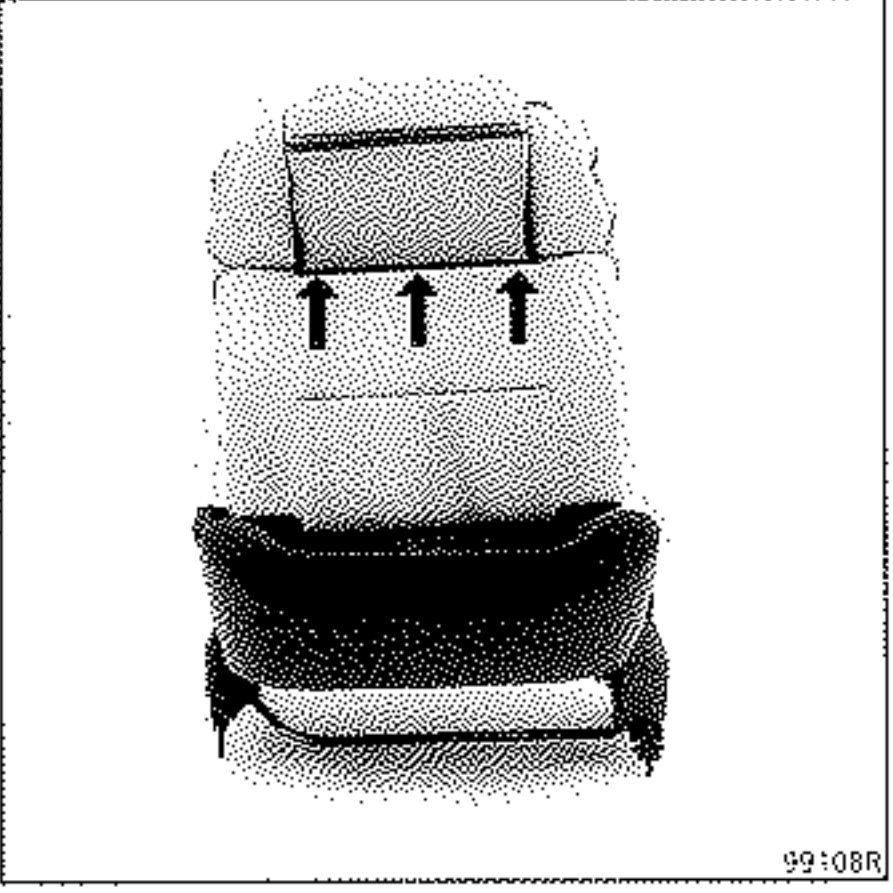

99108R

Continue folding back the trim and proceed in the same manner (three clips).

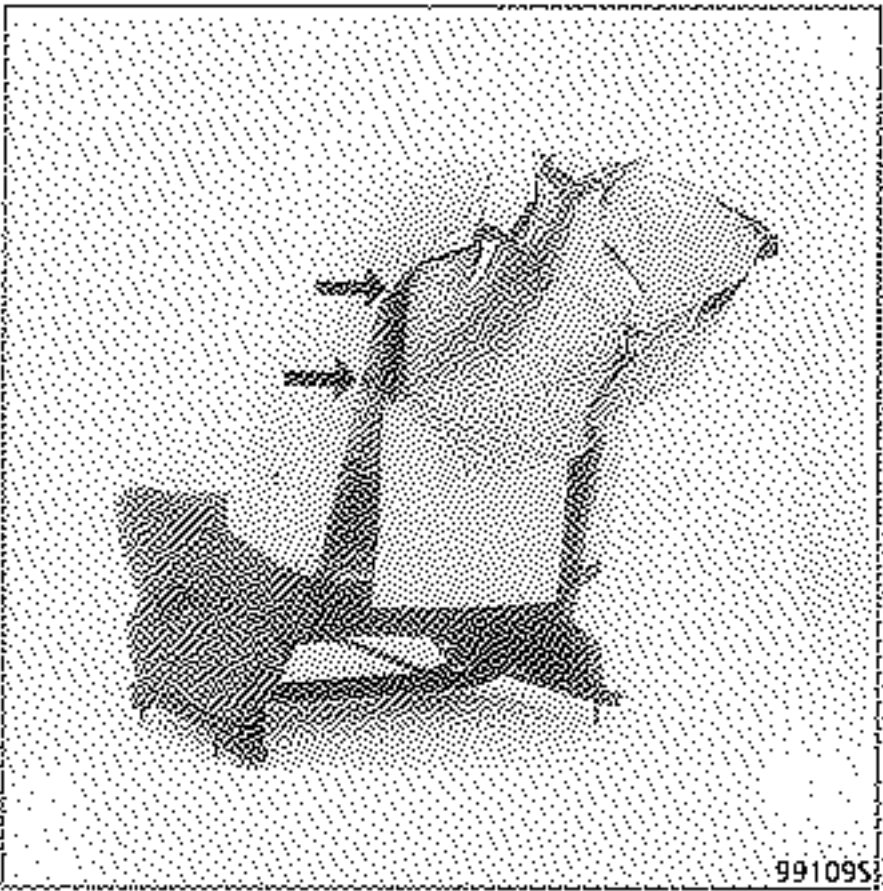

On the back of the seat, cut the four clips on the left and on the right hand sides.

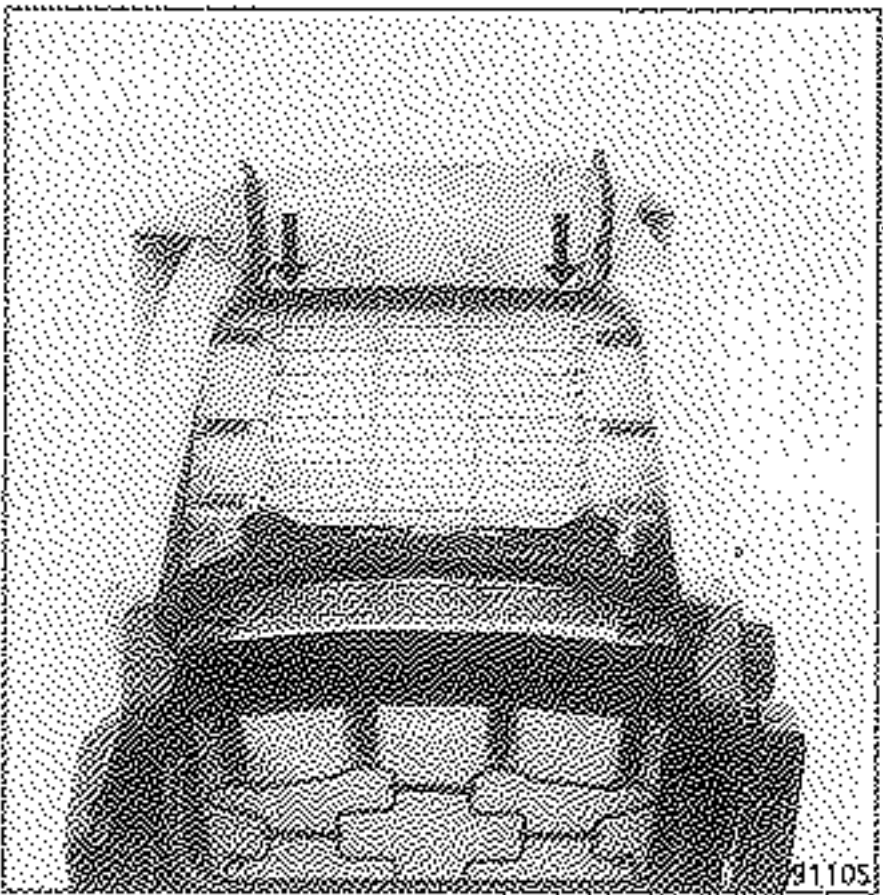

Turn the trim over and cut the two clips.

Remove the trim.

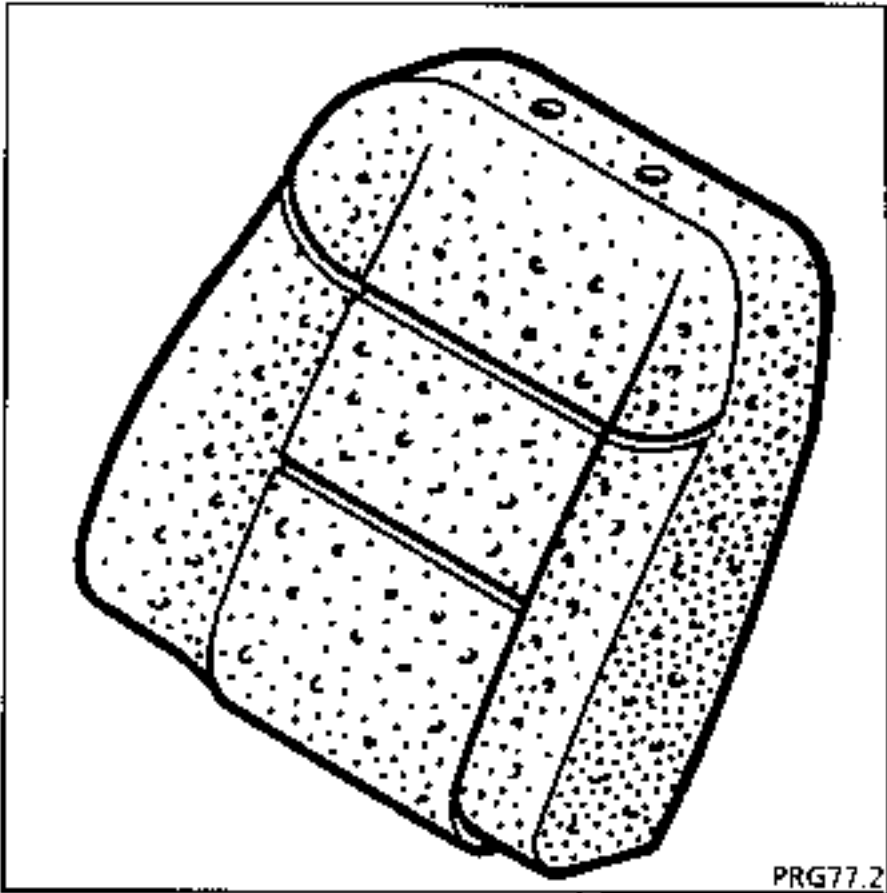

**IMPORTANT:**  
when refitting, do not tear the foam connectors, a difference in level between two parts will be visible when the seat trim has been refitted.

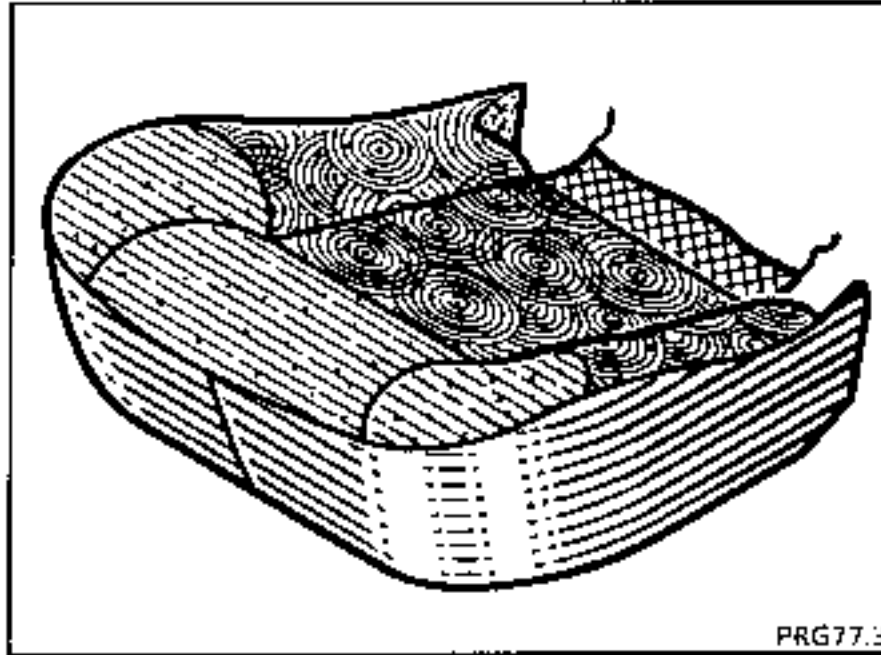

PRG77.3

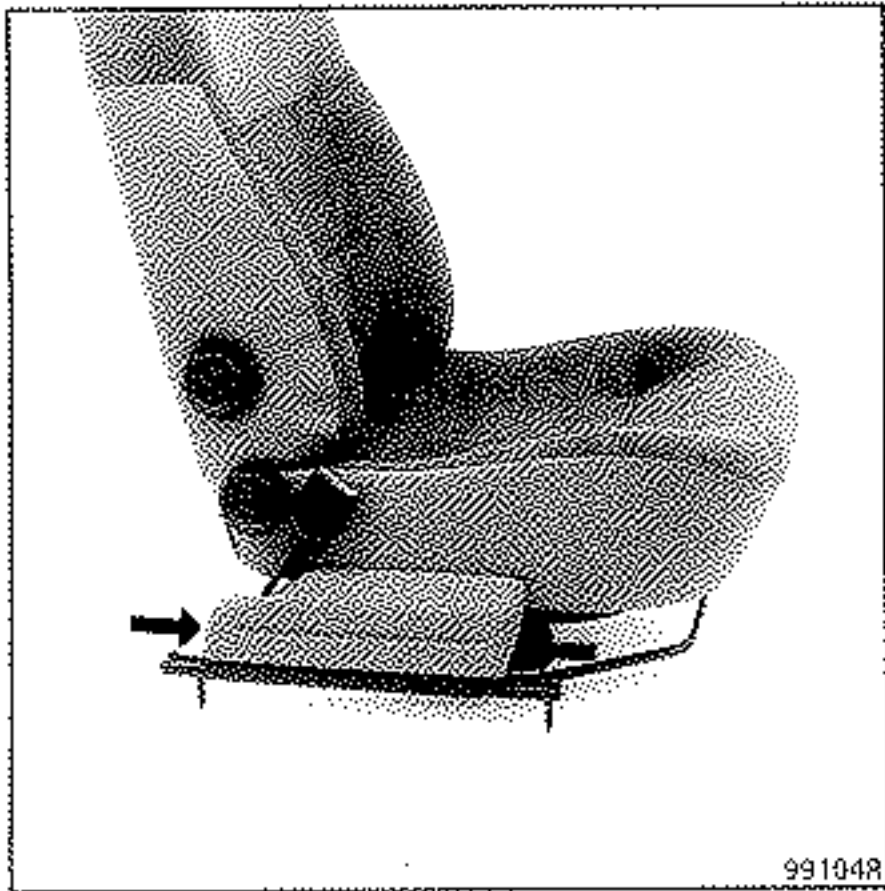

991048



991115

Remove the right hand runner cover and the central cover for the seatback angle adjustment wheel, then remove the wheel.

Remove the left hand runner cover.



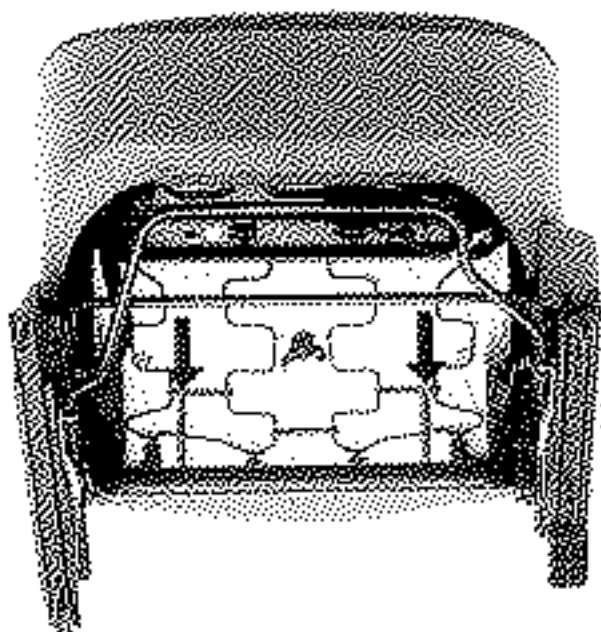

99112S

Cut the two clips on the foam sections under the seat squab.

Unclip the rear edge of the seatback and seat squab trim.

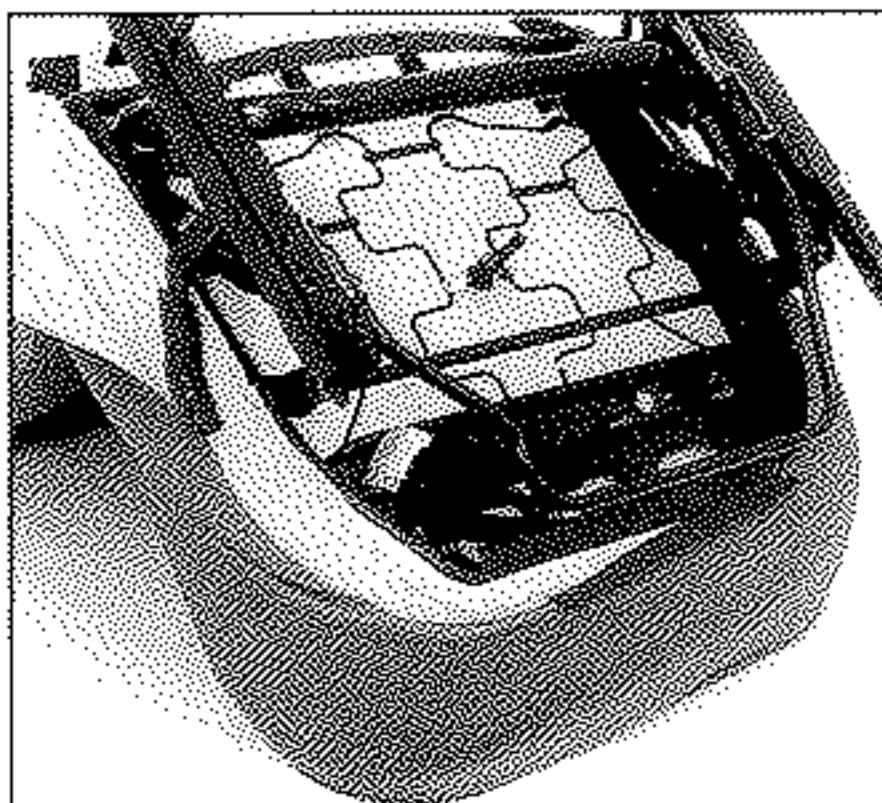

99113S

Unclip the front edge of the trim.

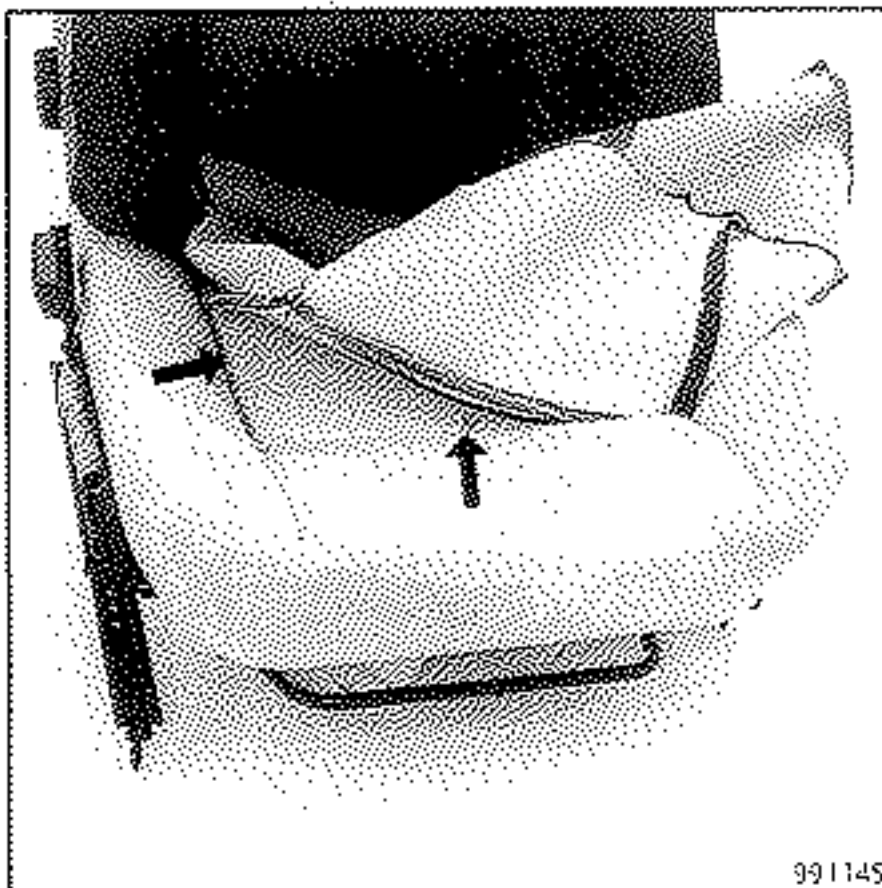

99114S

To replace the trim:

- turn the trim over to reach the inner clips,
- cut the clips and remove the trim.

To reach a motor:

- the trim does not need to be separated from the foam,
- without cutting the clips, remove the foam and trim assembly.

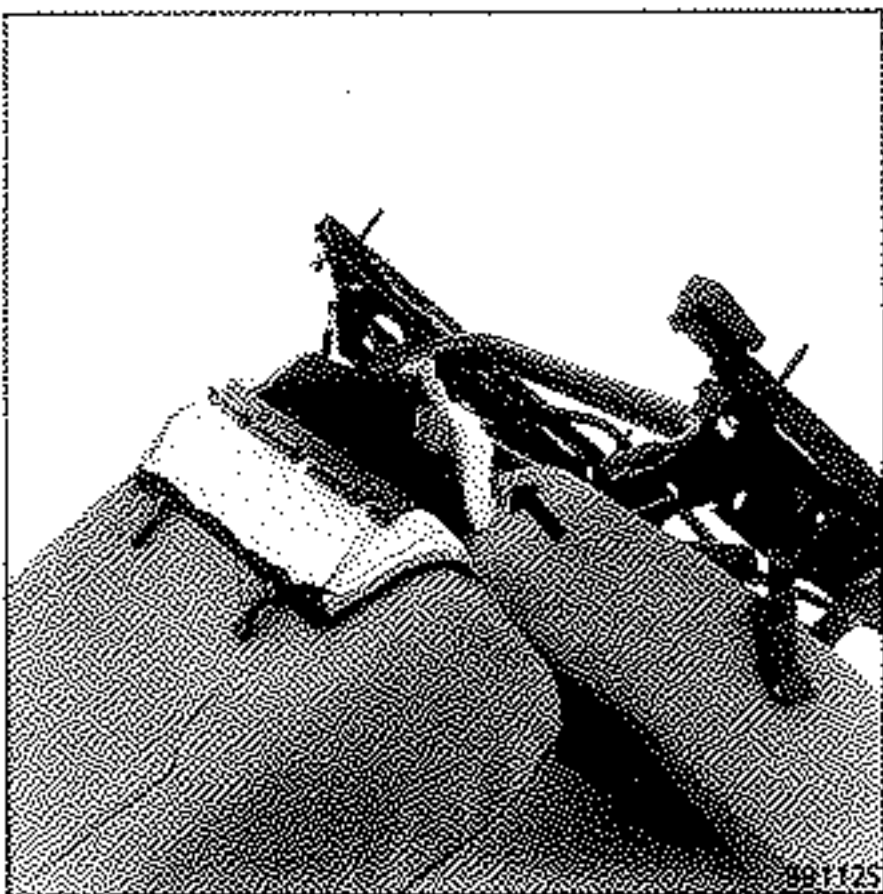

99112S

Remove the two metal clips.

Remove the two metal clips.

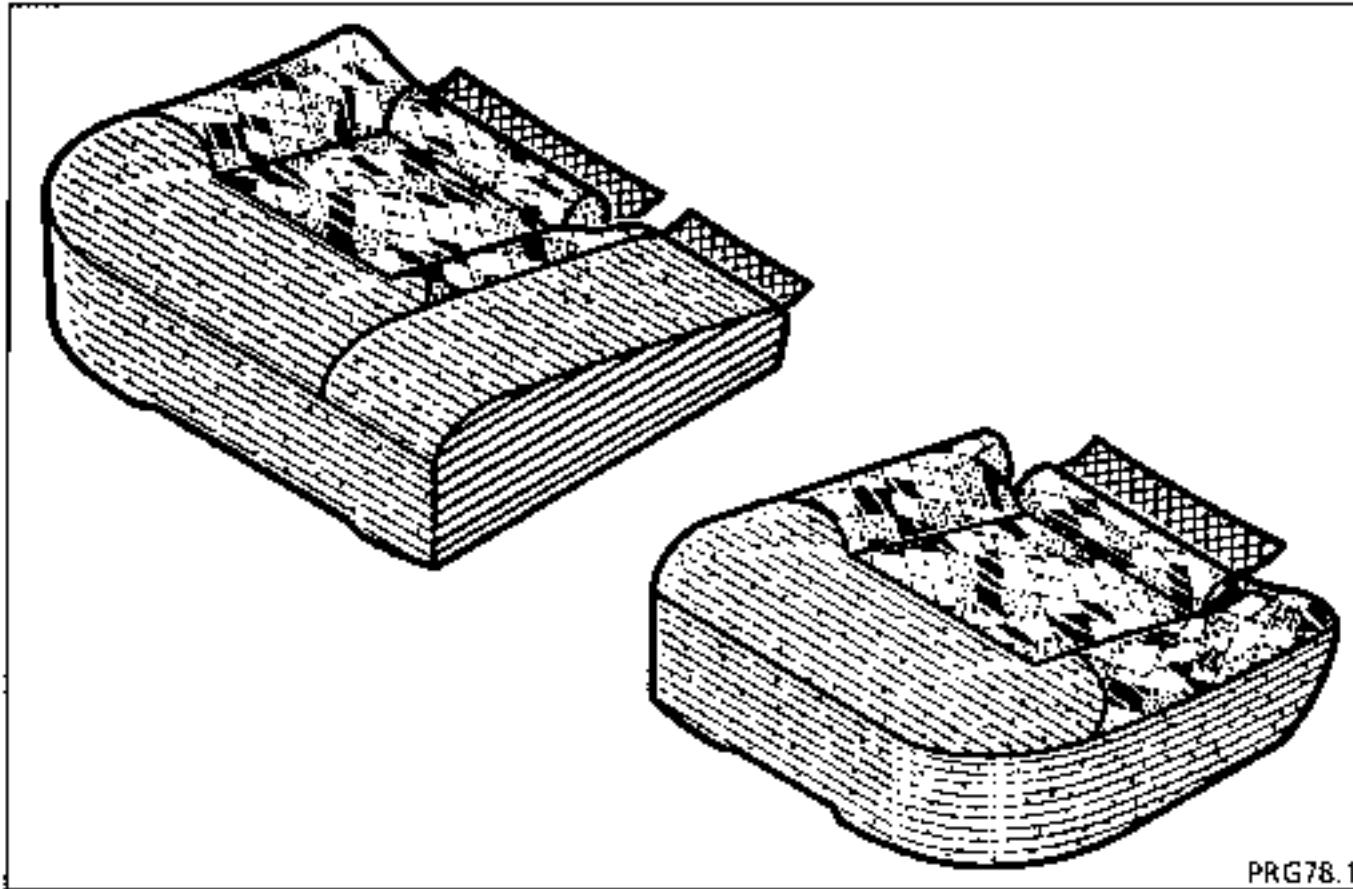

PRG78.1

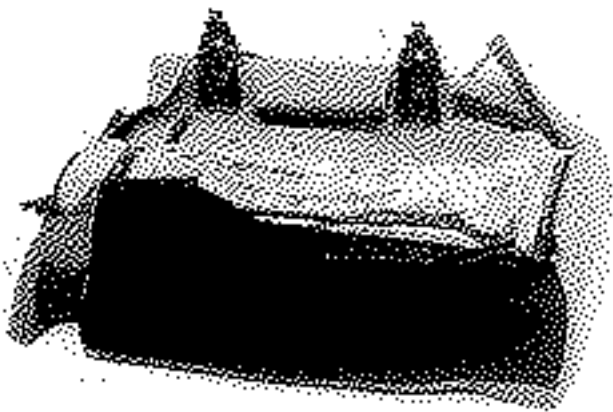

991155

Unclip the edge of the trim.

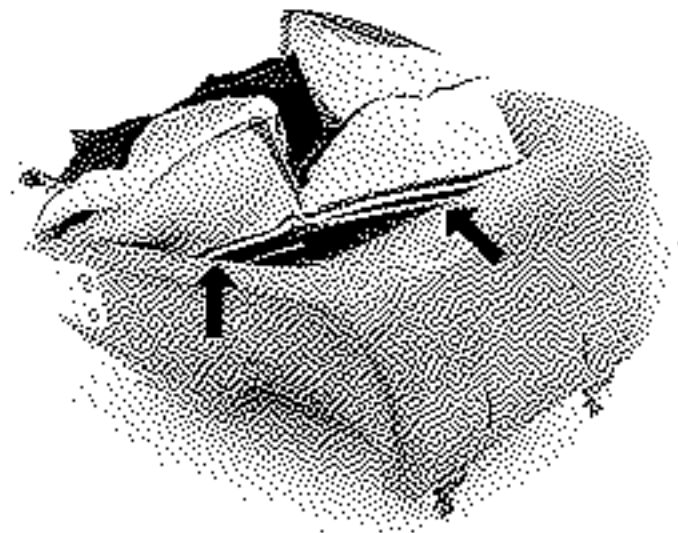

991165

Turn the trim over.

Cut the clips.

Separate the trim from the foam.

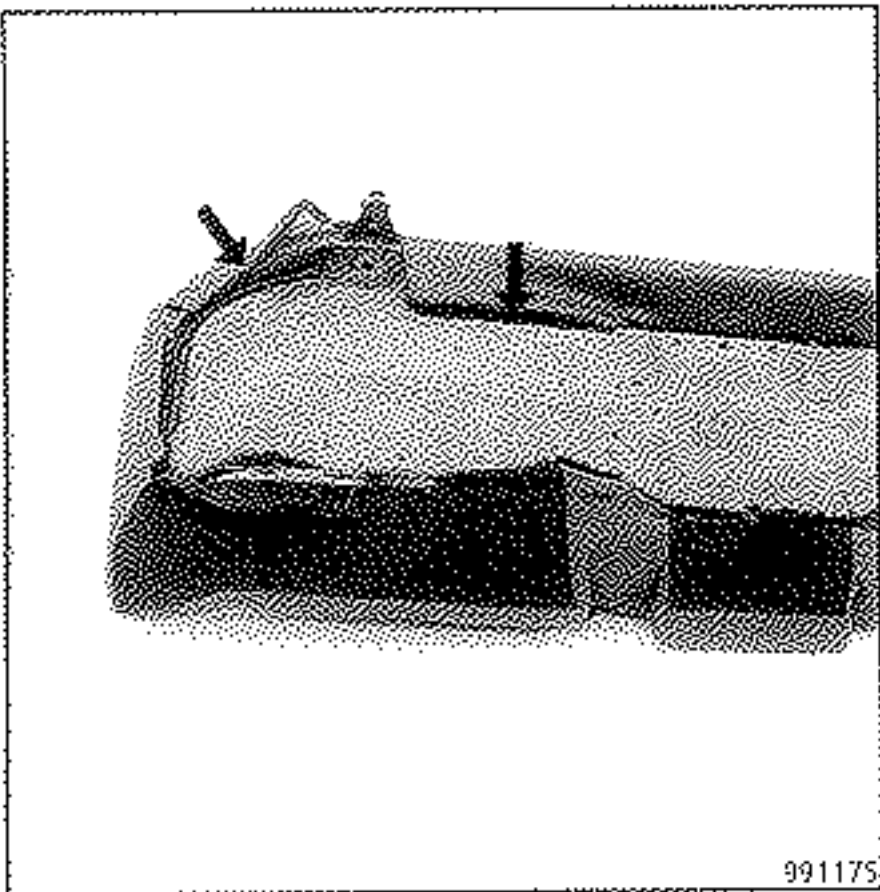
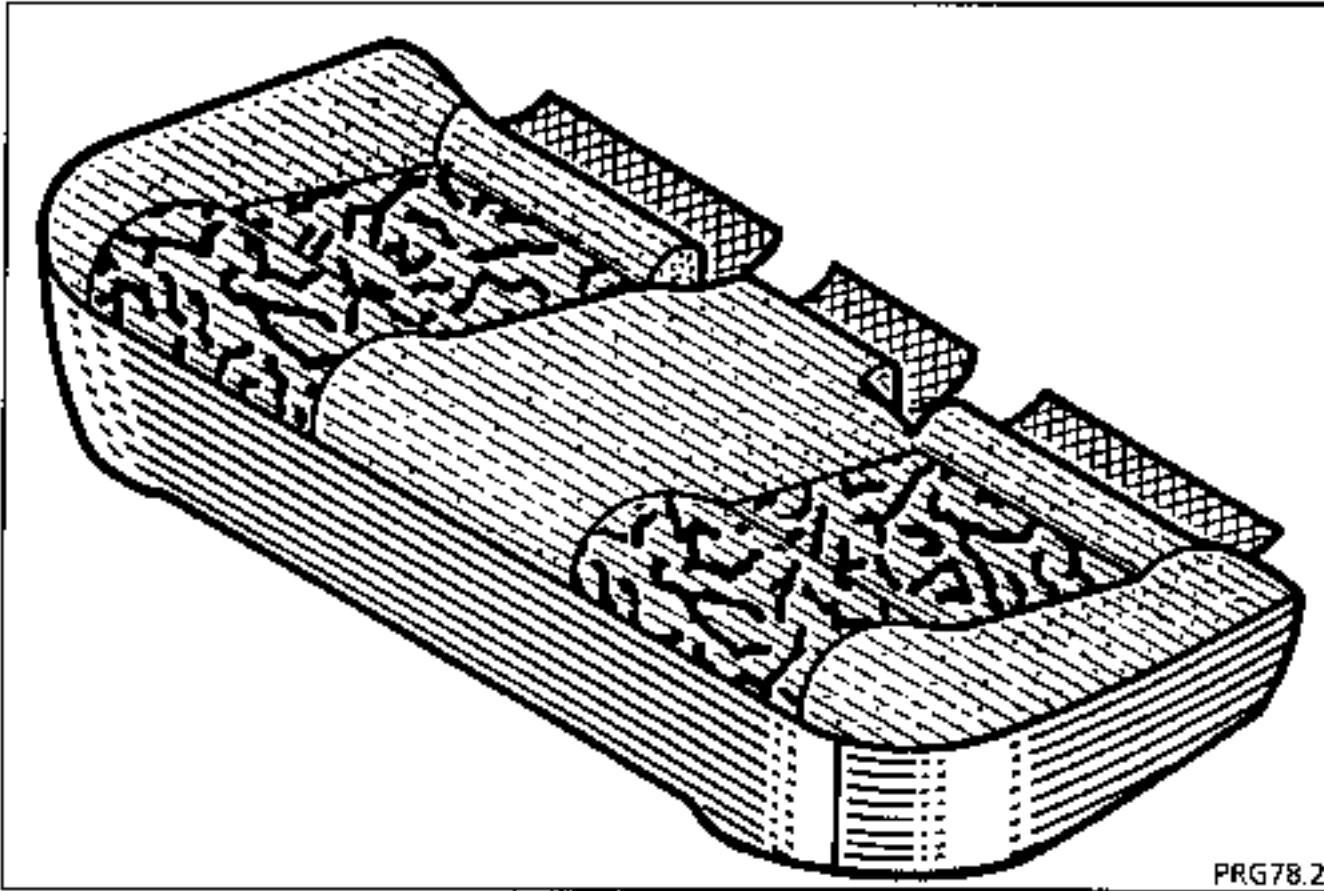

Unclip the edge of the trim.

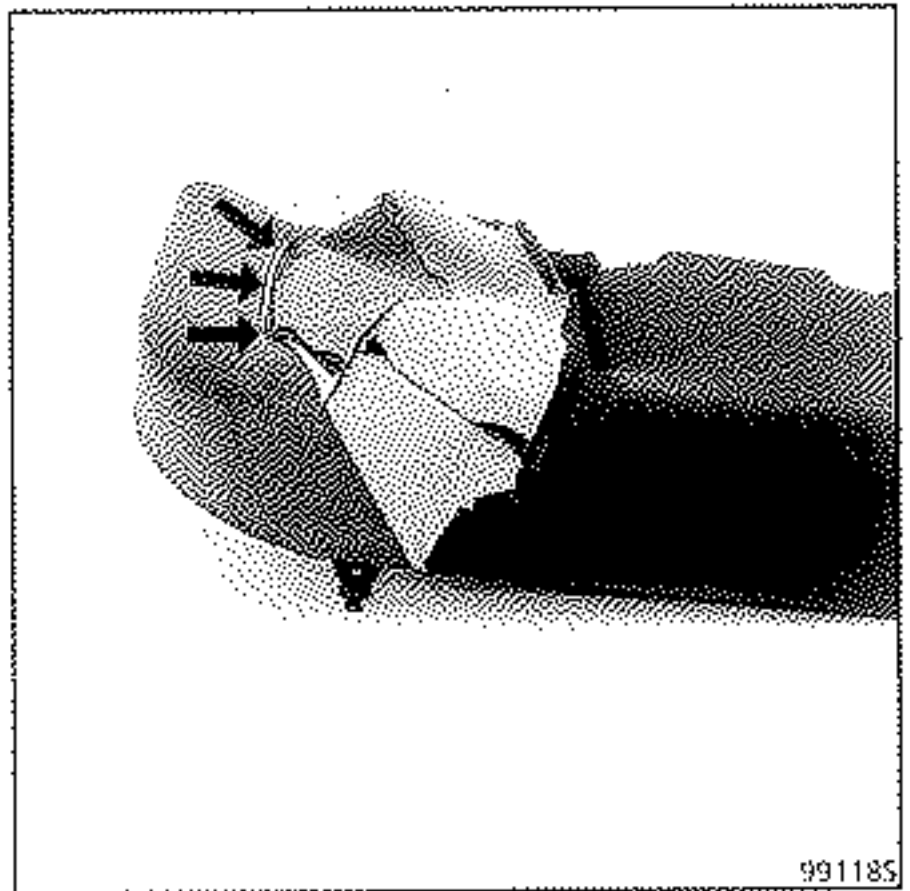

Turn the trim over.

Cut the clips.

Separate the trim from the foam.

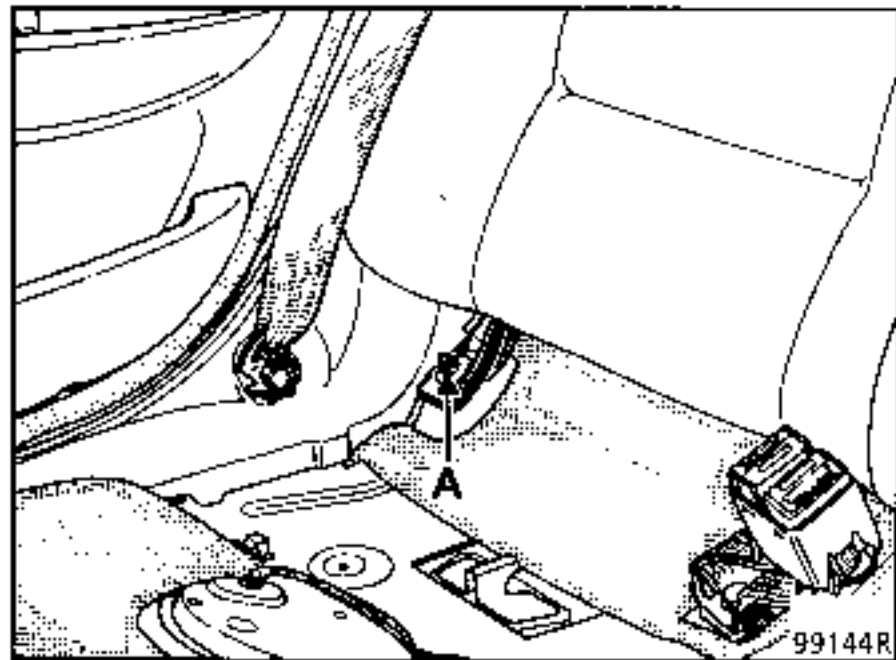
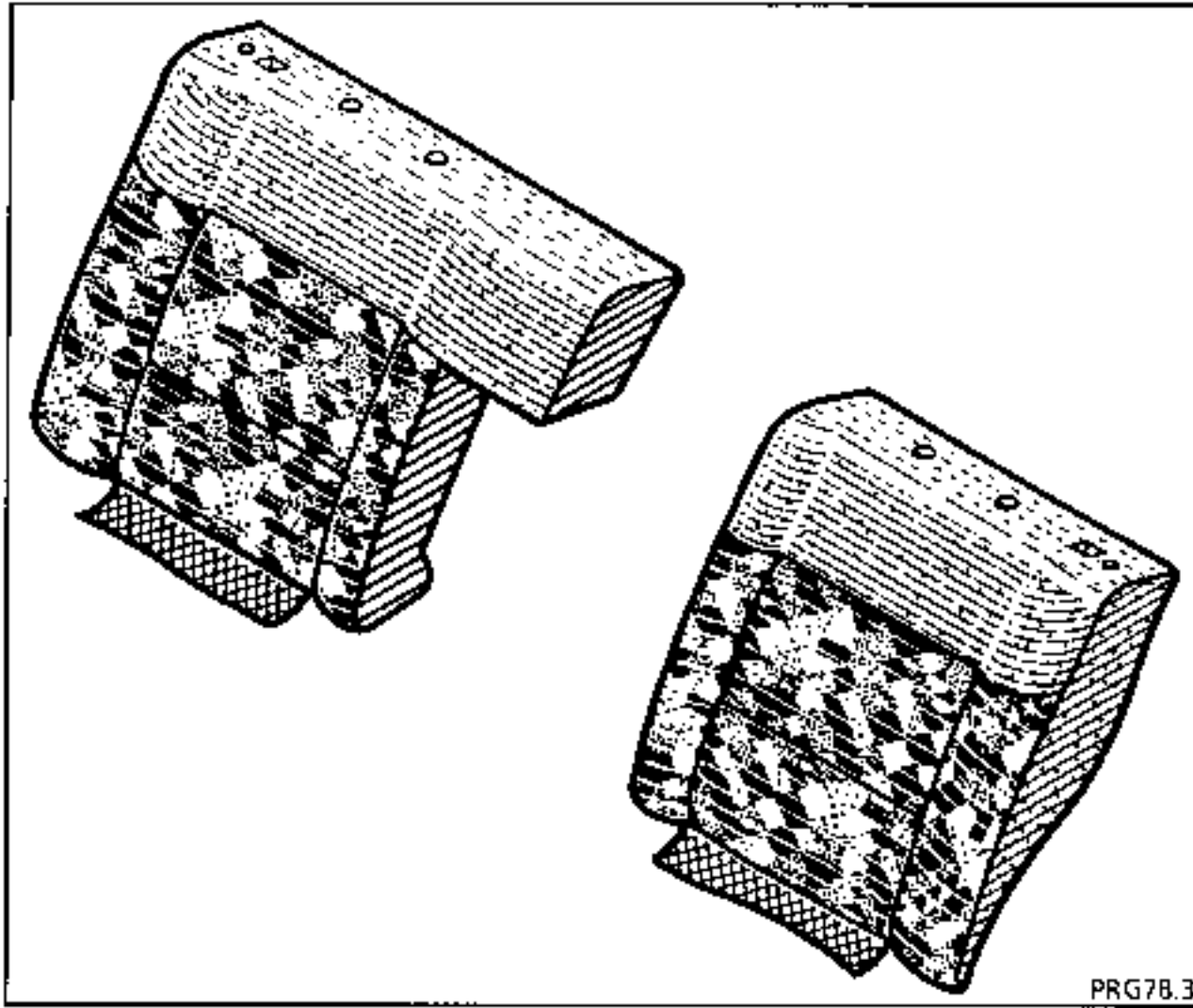

Tilt the seat squabs and remove the three seatback mounting nuts (A).

Remove the head restraints.

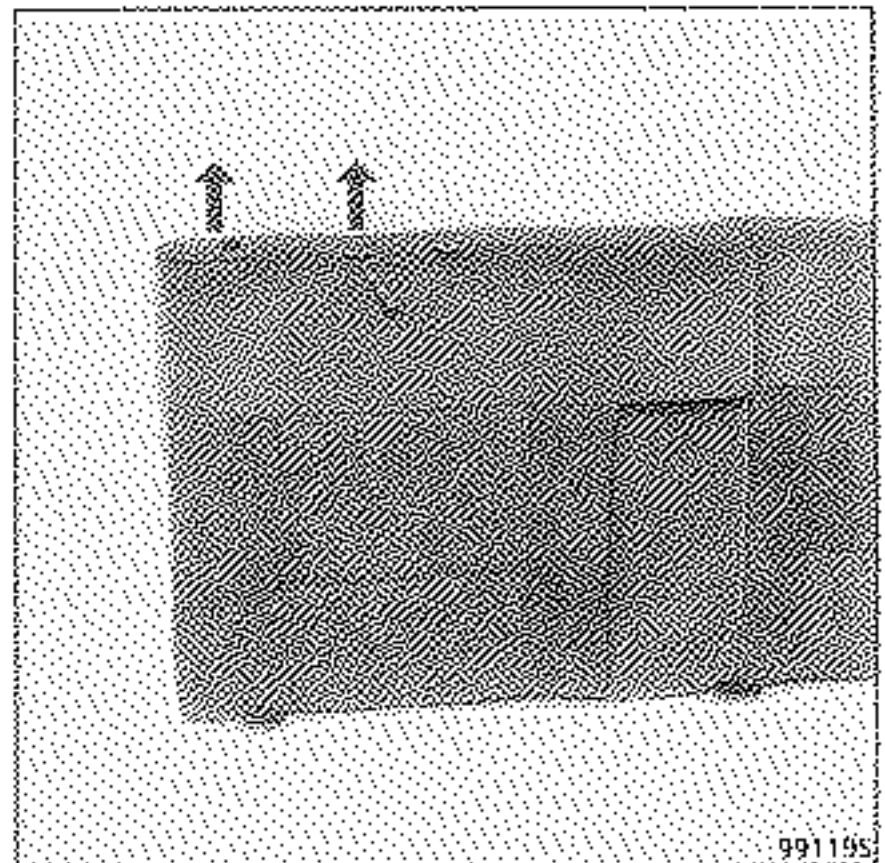

Remove the upper sections of the head restraints.

Unclip the lock control button surround.

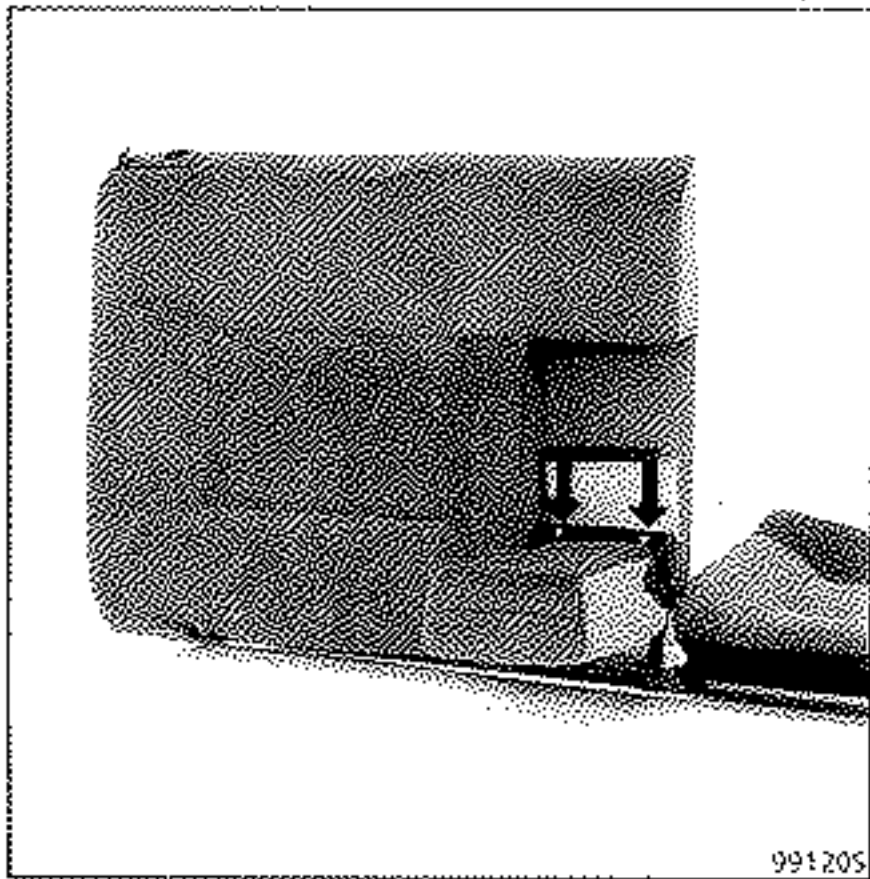

Remove the elbow rest (two bolts).

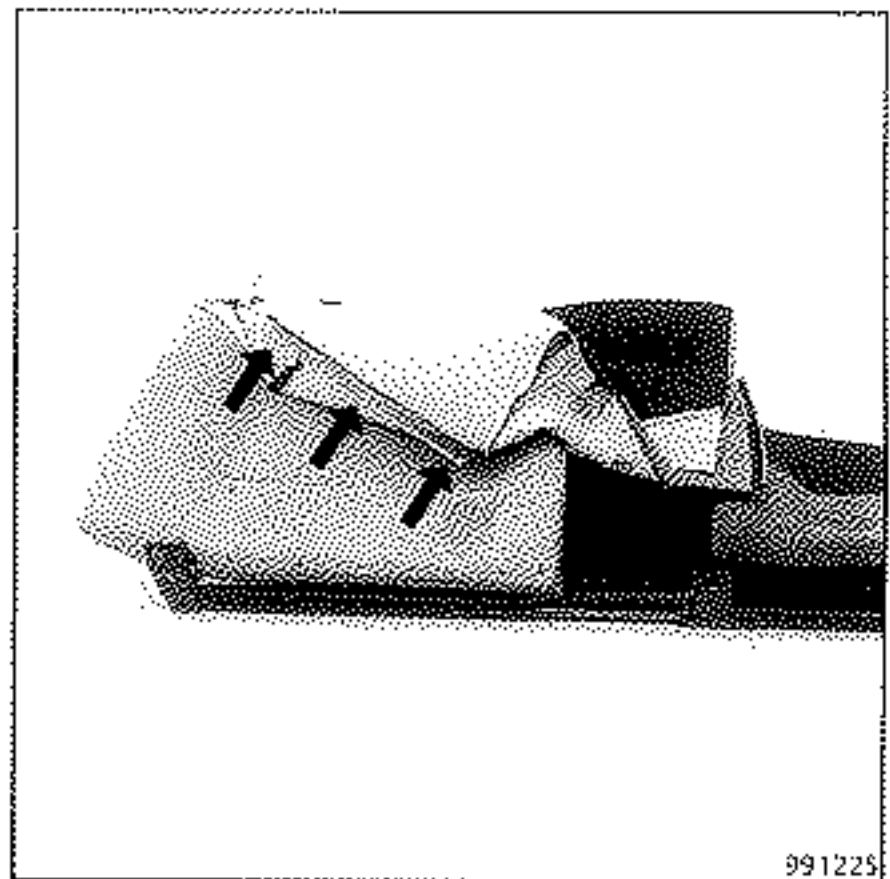

Turn the trim over and cut the clips.

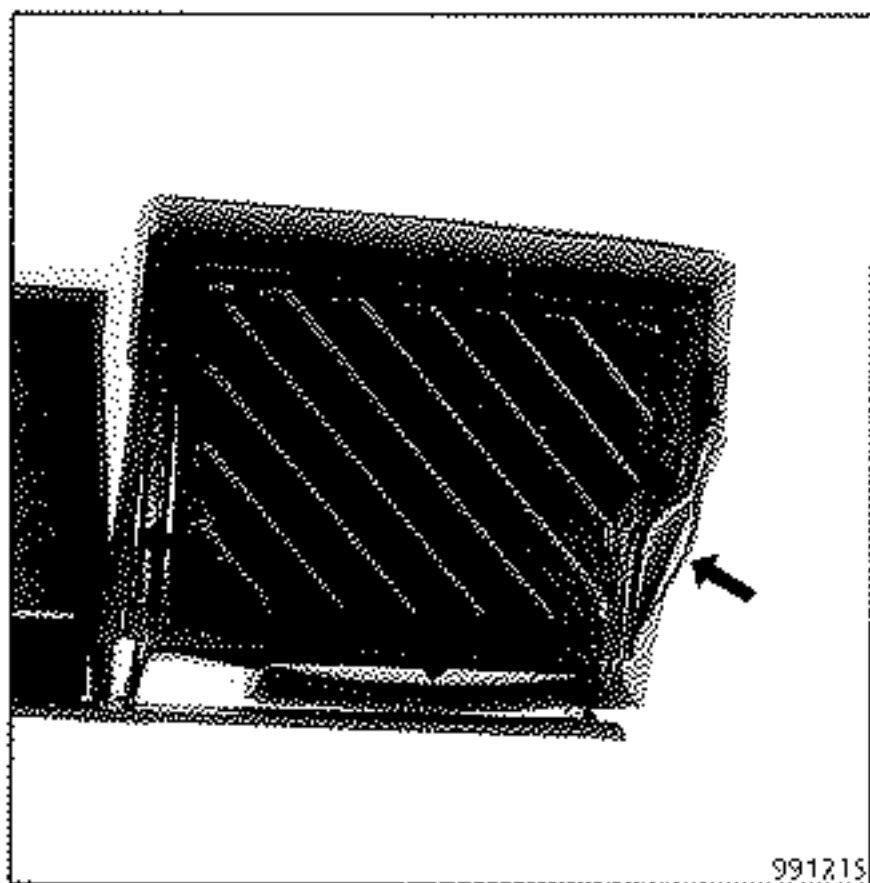

Unclip the lower sections of the trim on the left and right hand sides.

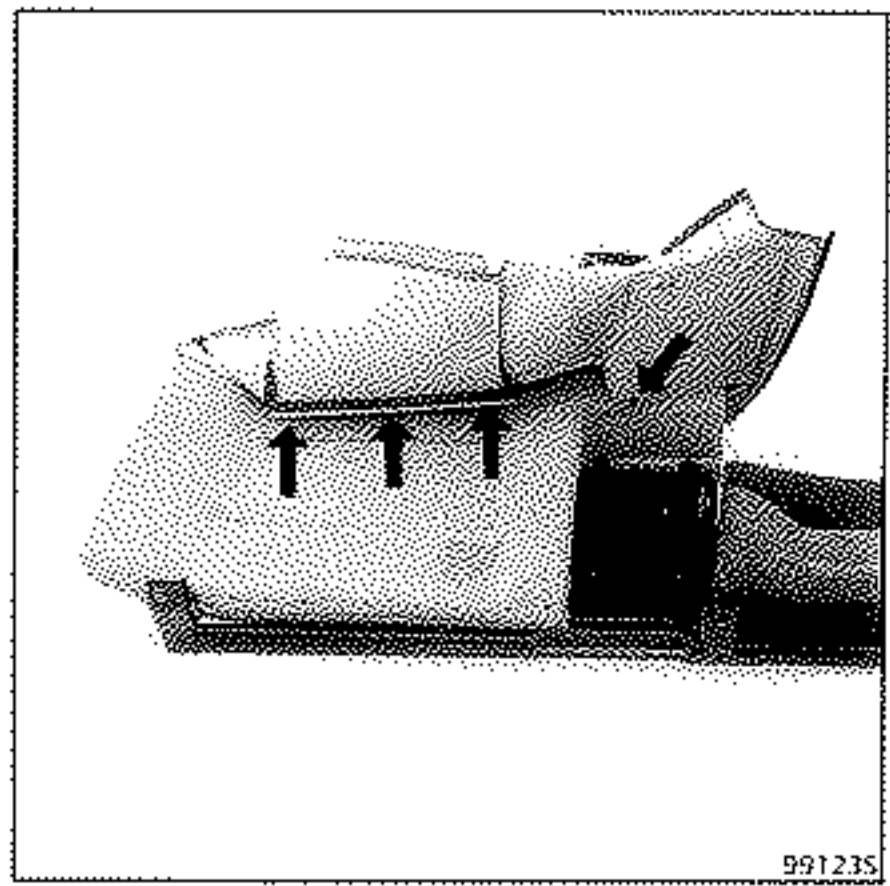

Continue moving the trim up.

Cut the clips (two types).

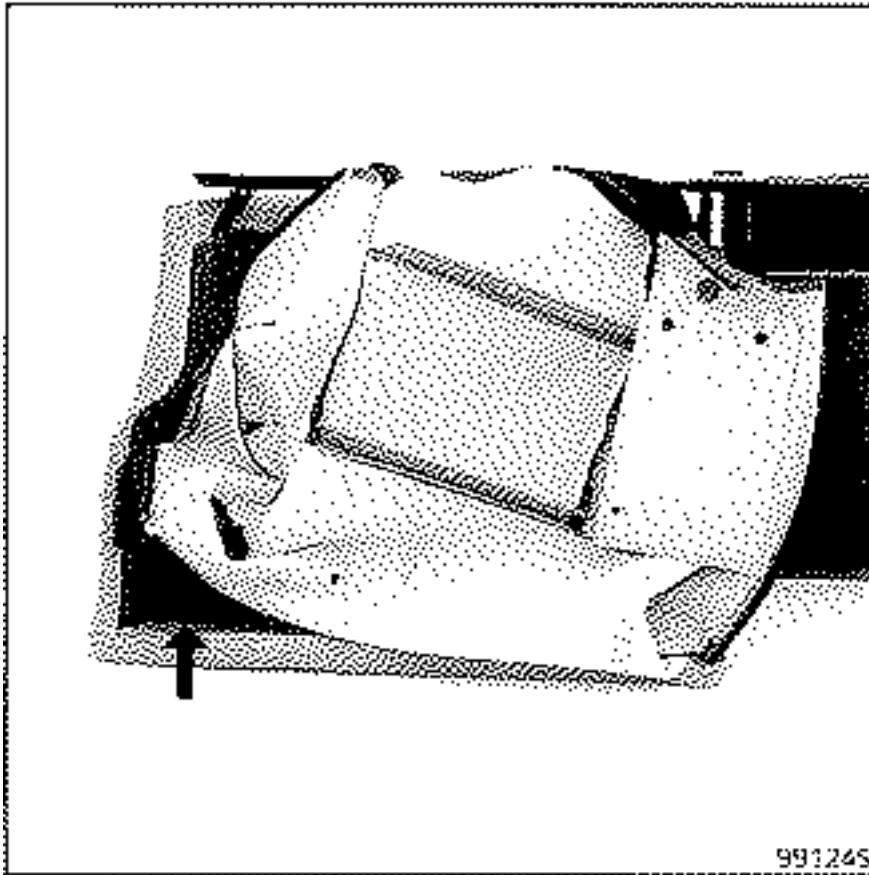

Turn the trim over and unclip the upper section.

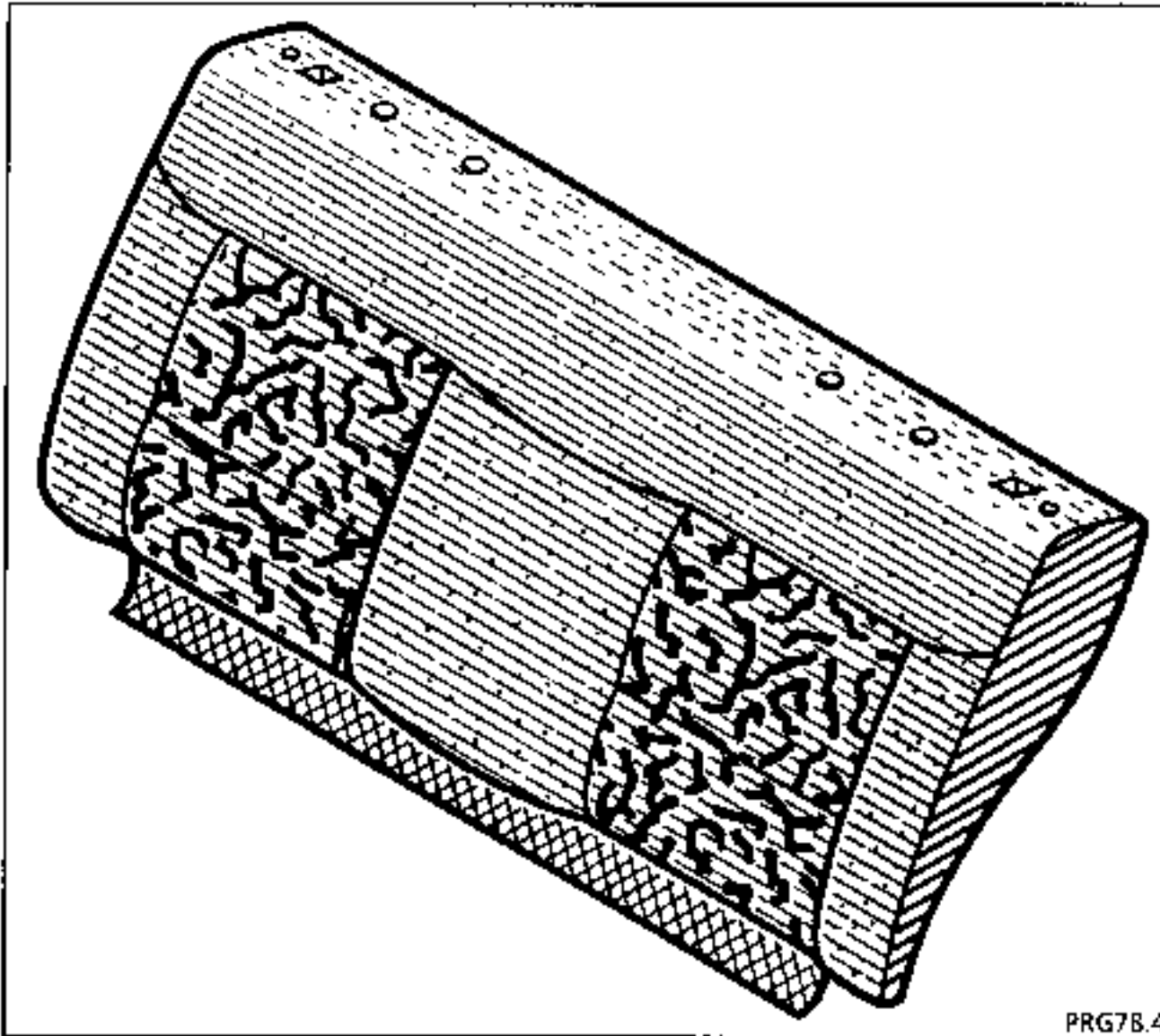

Remove:

- the rear seatback,
- the upper sections of the head restraint guide.

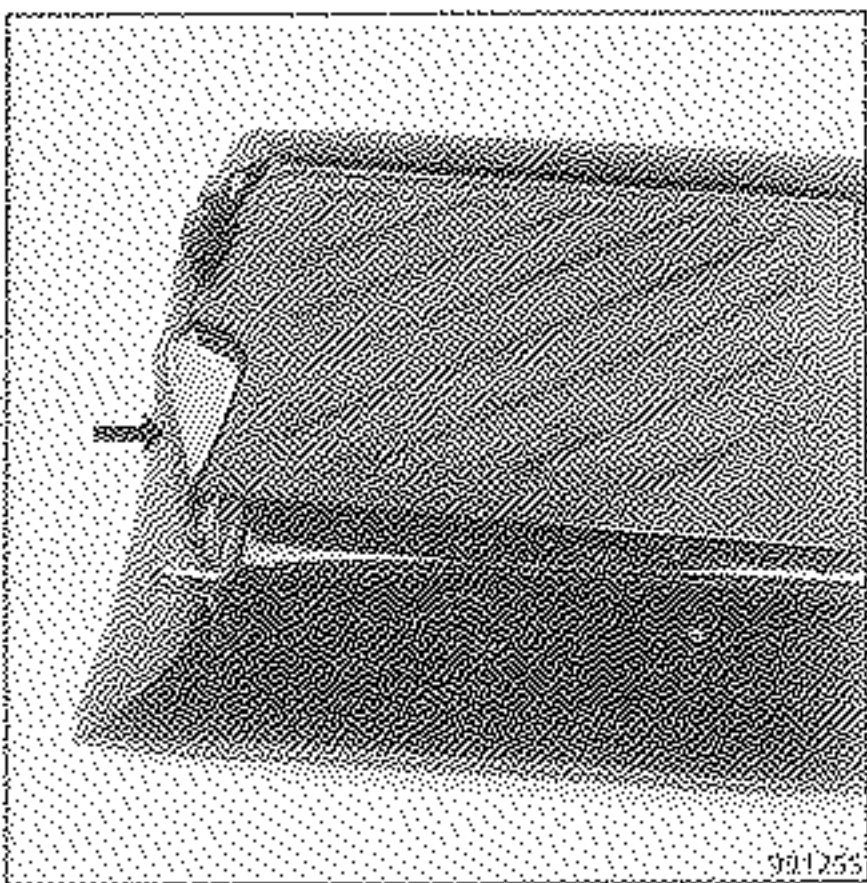

Unclip the lower sections of the trim on the left and right hand sides.

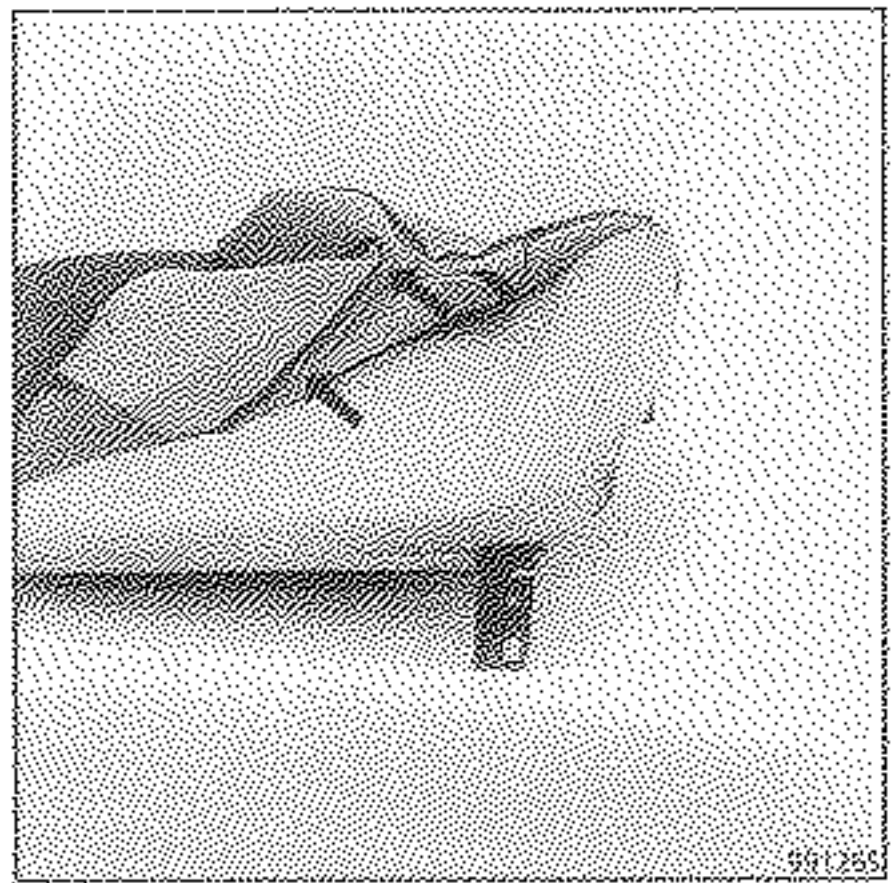

Turn the trim over and cut the clips.

Unclip the upper section.

Separate the trim from the foam.

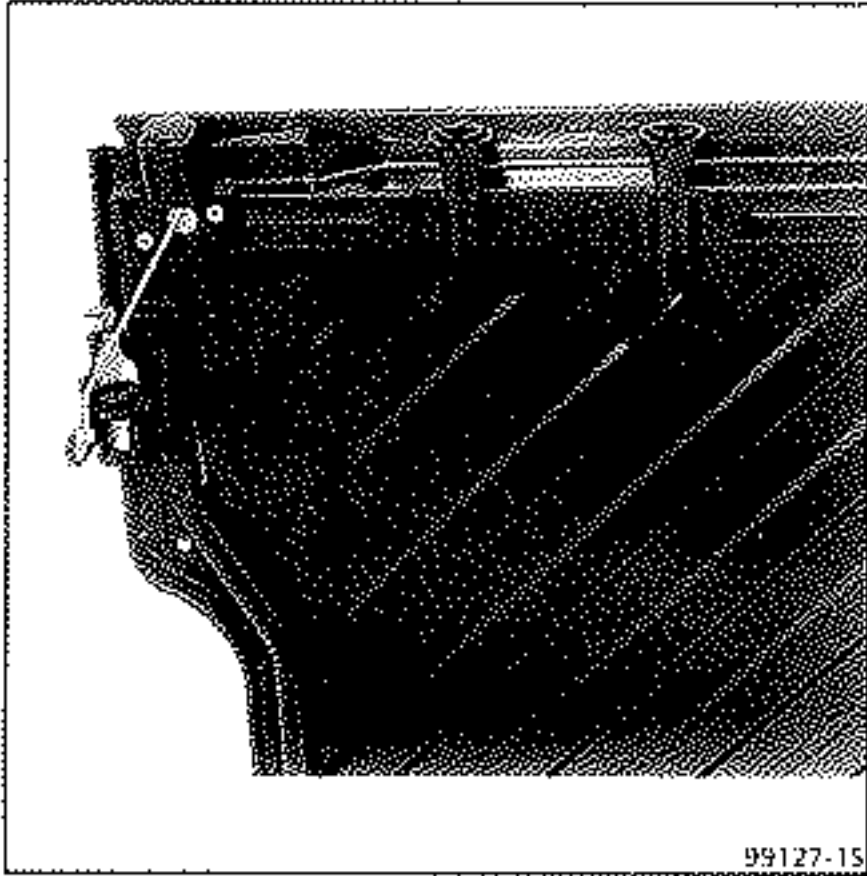

**Head restraint guides:**  
After removing the trim from the seatback, press on the tabs and remove the guides.

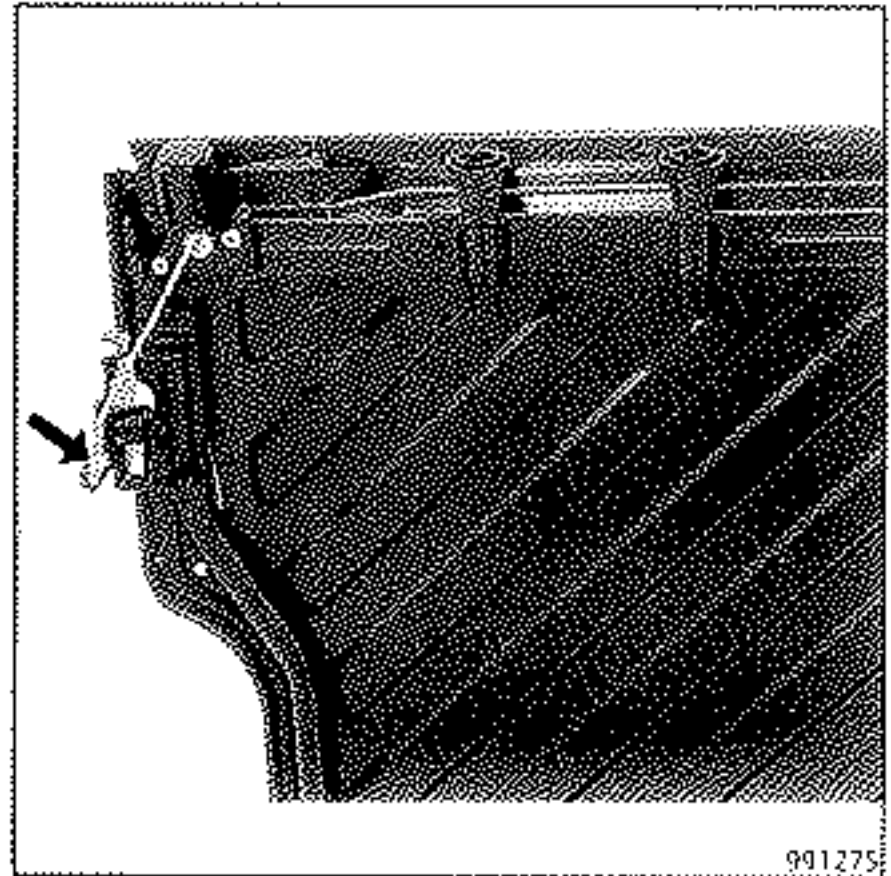

**Control button:**  
After removing the trim, remove the two rivets and unclip the linkage.

---

## Rear elbow rest

---

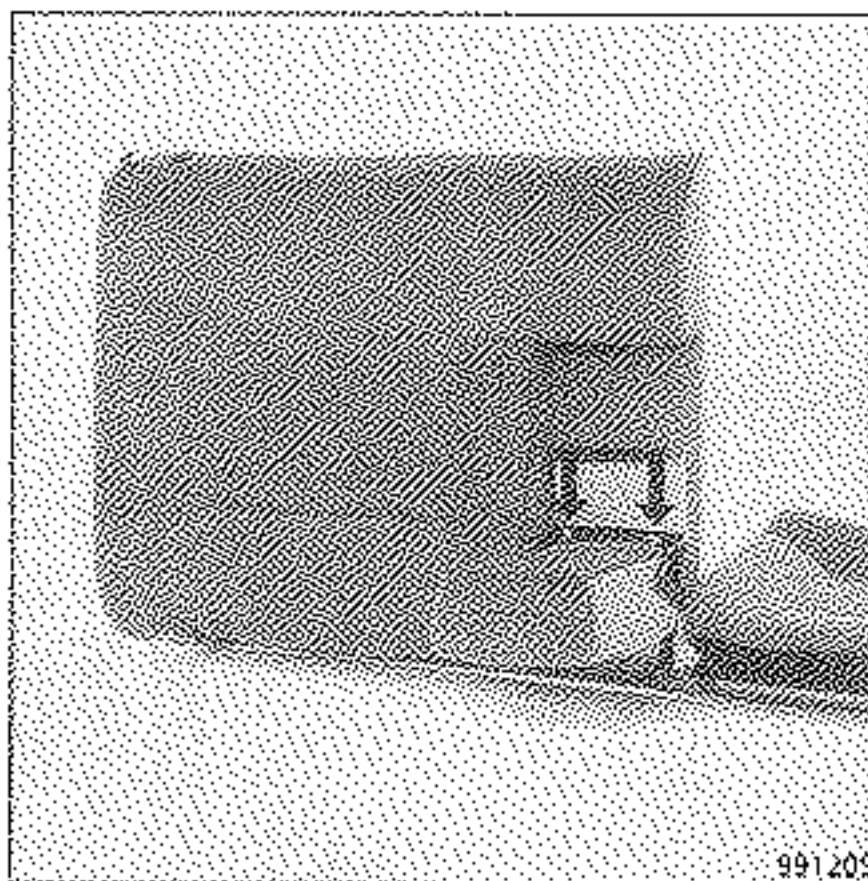

Remove the trim.  
Remove the two mounting bolts, Torx 30.