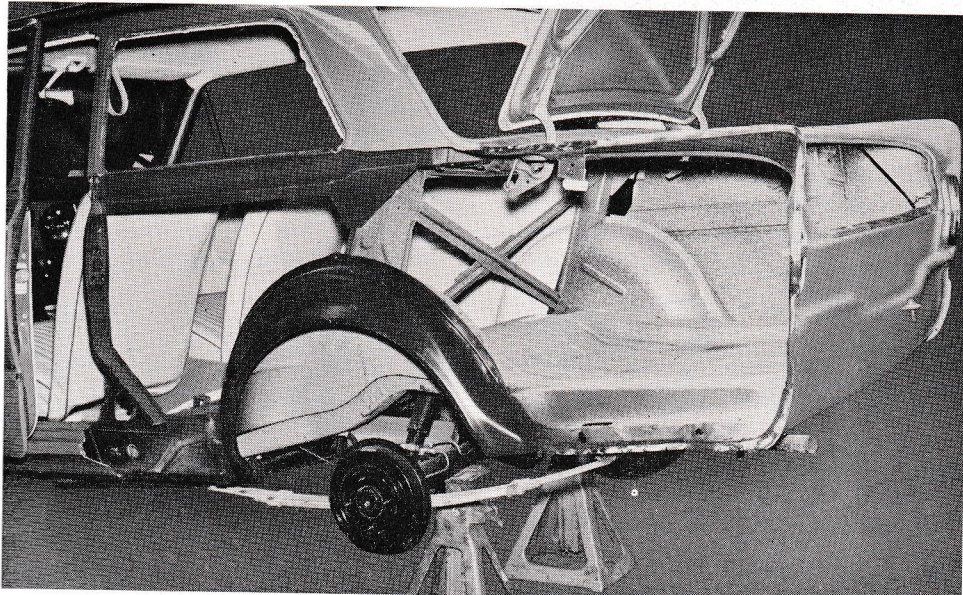

Fig. 100. The body side panel is serviced as a single item, and as the four separate sections as shown



SP 1999

Fig. 101. Showing the rear lower section of the body side panel removed. The cut edges of the panel must be subsequently trimmed to suit the new section, after this has been clamped in position

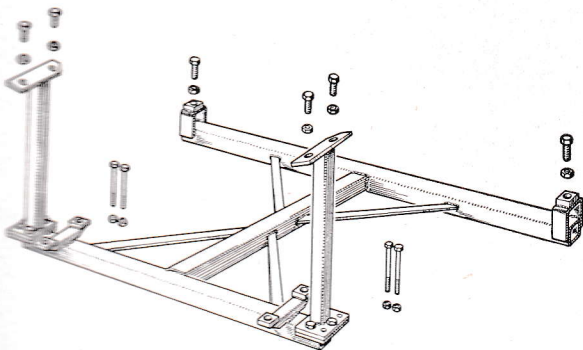
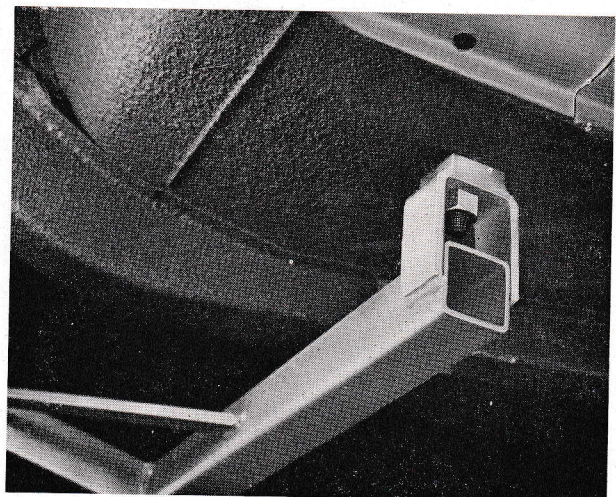

Fig. 102. Body Front End Assembly Frame D.1151, and attaching parts



SP 2000

Fig. 103. The body front end assembly frame is bolted to the underside of the floor panel as shown using the two forward manufacturing holes